

PRS-505

SERVICE MANUAL

Ver. 1.1 2007.12

US Model
Canadian Model



- SONY and the SONY logo are registered trademarks of Sony Corporation.
- BBEB, BBEB Book, and their logos are trademarks of Sony Corporation.
- "Memory Stick," "Memory Stick Duo," "Memory Stick PRO Duo," and their logos are trademarks of Sony Corporation.
- Bitstream is a registered trademark, and Dutch, Font Fusion, and Swiss are trademarks, of Bitstream Inc.
- Microsoft, Windows, Windows Vista and Windows Media are trademarks or registered trademarks of Microsoft Corporation in the United States and / or other countries.
- Adobe, Adobe Reader and Adobe PDF are trademarks or registered trademarks of Adobe Systems Incorporated in the United States and/or other countries.
- MPEG Layer-3 audio coding technology and patents licensed from Fraunhofer IIS and Thomson.Continued 90 US
- This product uses MontaVista Software, Inc.'s MontaVista(R) Linux(R) Professional Edition as the operating system. COPYRIGHT ©1999-2006 MONTAVISTA SOFTWARE, INC. ALL RIGHTS RESERVED. <http://www.mvista.com/>
- MontaVista is a registered trademark of MontaVista Software, Inc.
- This product includes software developed by the OpenSSL Project for use in the OpenSSL Toolkit. (<<http://www.openssl.org/>>) Copyright © 1998-2006 The OpenSSL Project. All rights reserved. This product includes cryptographic software written by Eric Young (eay@cryptsoft.com). This product includes software written by Tim Hudson (tjh@cryptsoft.com). For details on OpenSSL License, refer to "openssl.txt" on the CD-ROM.

All other system names and product names appearing in this document are generally the registered trademarks or trademarks of their respective manufacturers. Further, the trademark TM and registered trademark ® symbols are not indicated throughout this document.

Program ©2006, 2007 Sony Corporation
Documentation ©2006, 2007 Sony Corporation

SPECIFICATIONS

Power source

Built-in rechargeable battery: DC 3.7 V
AC power adapter: DC 5.2 V

Battery life (continuous playback)

Approx. 7500 pages (when the battery is fully charged)

User available capacity

Approx. 192MB
Available storage capacity of the Reader may vary.

Operating temperature

5 to 35 °C (41 to 95 °F)

Dimensions (w/h/d)

Approx. 6.9 × 4.8 × 0.3 inches (maximum, without soft cover)

Mass

Approx. 9 oz (without soft cover)

Package Contents

The Reader comes installed with a built-in rechargeable battery.

- Reader (with Soft cover) (1)
- USB cable (1)
- CD-ROM (1)
 - eBook Library software
 - User's Guide (PDF)
 - Sample contents
- Quick Start Guide (this manual) (1)
- Flyers
- Dummy cards (2)

Note

- This CD-ROM will not play in an audio CD player.

Design and specifications are subject to change without notice.

PORTABLE READER SYSTEM

9-887-835-02 Sony Corporation
2007L05-1 Audio Business Group
© 2007.12 Published by Sony Techno Create Corporation

SONY®

TABLE OF CONTENTS

1. **SERVICING NOTES** 3

2. **GENERAL** 5

3. **DISASSEMBLY**

3-1. Disassembly Flow 6

3-2. Ornamental Plate (Upper) Assy, Plate (Case_Upper) 6

3-3. Ornamental Plate (Lower) Assy..... 7

3-4. Main Assy 7

3-5. (Ion) Storage Battery Assy 8

3-6. SLOT FLEXIBLE Board 8

3-7. CONNECT FLEXIBLE Board 9

3-8. Frame 9

3-9. MAIN Board, Ink (Indication) Element Assy (IIE1)..... 10

4. **TEST MODE** 11

5. **ELECTRICAL ADJUSTMENT** 11

6. **DIAGRAMS**

6-1. Block Diagram - MAIN Section (1/2) - 12

6-2. Block Diagram - MAIN Section (2/2) - 13

6-3. Block Diagram - KEY/POWER SUPPLY Section -..... 14

6-4. Printed Wiring Board
- MAIN Board (Component Side) - 16

6-5. Printed Wiring Board
- MAIN Board (Conductor Side) - 17

6-6. Schematic Diagram - MAIN Board (1/10) - 18

6-7. Schematic Diagram - MAIN Board (2/10) - 19

6-8. Schematic Diagram - MAIN Board (3/10) - 20

6-9. Schematic Diagram - MAIN Board (4/10) - 21

6-10. Schematic Diagram - MAIN Board (5/10) - 22

6-11. Schematic Diagram - MAIN Board (6/10) - 23

6-12. Schematic Diagram - MAIN Board (7/10) - 24

6-13. Schematic Diagram - MAIN Board (8/10) - 25

6-14. Schematic Diagram - MAIN Board (9/10) - 26

6-15. Schematic Diagram - MAIN Board (10/10) - 27

6-16. Printed Wiring Board
- CONNECT FLEXIBLE Board - 28

6-17. Schematic Diagram
- CONNECT FLEXIBLE Board - 28

7. **EXPLODED VIEWS**

7-1. Case Section 44

7-2. Main Section 45

8. **ELECTRICAL PARTS LIST** 46

Notes on chip component replacement

- Never reuse a disconnected chip component.
- Notice that the minus side of a tantalum capacitor may be damaged by heat.

Flexible Circuit Board Repairing

- Keep the temperature of soldering iron around 270 °C during repairing.
- Do not touch the soldering iron on the same conductor of the circuit board (within 3 times).
- Be careful not to apply force on the conductor when soldering or unsoldering.

CAUTION

Danger of explosion if battery is incorrectly replaced. Replace only with the same or equivalent type.

SAFETY-RELATED COMPONENT WARNING!

COMPONENTS IDENTIFIED BY MARK \triangle OR DOTTED LINE WITH MARK \triangle ON THE SCHEMATIC DIAGRAMS AND IN THE PARTS LIST ARE CRITICAL TO SAFE OPERATION. REPLACE THESE COMPONENTS WITH SONY PARTS WHOSE PART NUMBERS APPEAR AS SHOWN IN THIS MANUAL OR IN SUPPLEMENTS PUBLISHED BY SONY.

ATTENTION AU COMPOSANT AYANT RAPPORT À LA SÉCURITÉ!

LES COMPOSANTS IDENTIFIÉS PAR UNE MARQUE \triangle SUR LES DIAGRAMMES SCHÉMATIQUES ET LA LISTE DES PIÈCES SONT CRITIQUES POUR LA SÉCURITÉ DE FONCTIONNEMENT. NE REMPLACER CES COM- POSANTS QUE PAR DES PIÈCES SONY DONT LES NUMÉROS SONT DON- NÉS DANS CE MANUEL OU DANS LES SUPPLÉMENTS PUBLIÉS PAR SONY.

SECTION 1 SERVICING NOTES

UNLEADED SOLDER

Boards requiring use of unleaded solder are printed with the lead-free mark (LF) indicating the solder contains no lead.
(Caution: Some printed circuit boards may not come printed with the lead free mark due to their particular size)

LF : LEAD FREE MARK

Unleaded solder has the following characteristics.

- Unleaded solder melts at a temperature about 40 °C higher than ordinary solder.
Ordinary soldering irons can be used but the iron tip has to be applied to the solder joint for a slightly longer time.
Soldering irons using a temperature regulator should be set to about 350 °C.
Caution: The printed pattern (copper foil) may peel away if the heated tip is applied for too long, so be careful!
- Strong viscosity
Unleaded solder is more viscous (sticky, less prone to flow) than ordinary solder so use caution not to let solder bridges occur such as on IC pins, etc.
- Usable with ordinary solder
It is best to use only unleaded solder but unleaded solder may also be added to ordinary solder.

REWRITING THE LUT

The LUT is exclusive for each lot number of the INK INDICATOR ELEMENT ASSY. Therefore, when replacing the MAIN board, display panel, or FLASH ROM, you need to rewrite the LUT. However, rewriting is not required if the lot number is the same.

Location where the LUT is stored:

- IC1203

How to check the version of the stored LUT:

- When you insert the memory stick or SD memory card in which the exclusive file is stored, the test mode is established. Check the current LUT version displayed at the right side of "Update Waveform" as in the screen below. The LUT version is "8202191919" in this example.

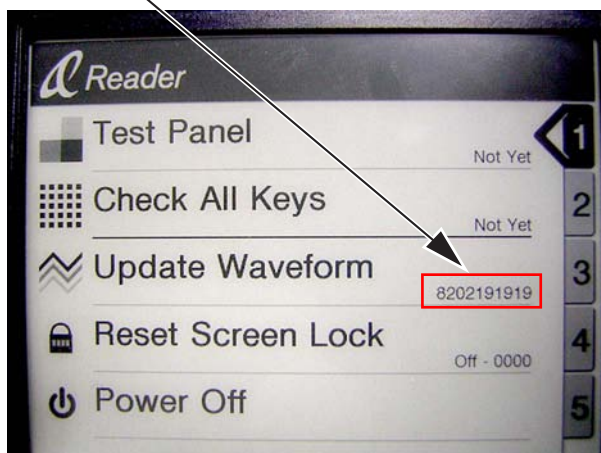

(Screen display)

How to check the lot number of the ink (indication)

ELEMENT ASSY:

- The lot number is written on the label on the flexible card wire. The lot number is "P10" in the picture below.

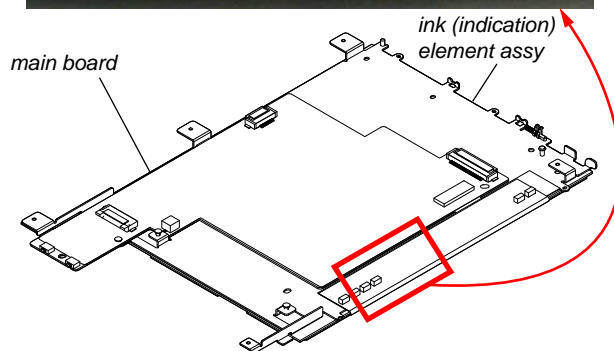
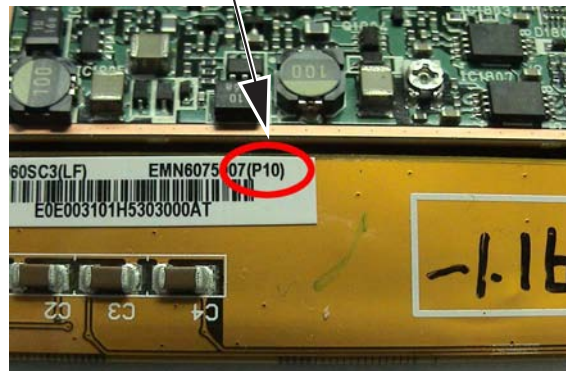

How to change the LUT:

- Copy the LUT file you want to update to the folder under "/ Sony Reader/software" in the memory stick or SD memory card exclusive for the test mode, and then change the name to "lut.bin". Execute test mode No.3 "Update Waveform". The LUT will be updated in about 10 seconds, and the LUT version display will also change.
- For the LUT version and the LUT file corresponding to the lot number of the panel, refer to technical news.

Note:

- To create the memory stick exclusive for the test mode, refer to TEST MODE (Page 11).
- For the VCOM adjustment value of RV1801 for each lot, refer to ELECTRICAL ADJUSTMENT (Page 11).

NOTE THE IC1001 ON THE MAIN BOARD REPLACING

Replacement of IC1001 on the MAIN board used in this set requires a special tool

NOTE THE IC301, IC953, IC1106, IC1201, IC1202 AND IC1203 ON THE MAIN BOARD REPLACING

When IC301, IC953, IC1106, IC1201, IC1202 and IC1203 on the MAIN board is damaged, exchange the new MAIN board for the MAIN board which IC damaged

NOTES WHEN REPLACING THE INK INDICATOR ELEMENT ASSY, MAIN BOARD AND FLASH ROM (IC1203)

When the INK INDICATOR ELEMENT ASSY, MAIN board, or FLASH ROM (IC1203) is replaced, you need to change the LUT.

REMOVING/ATTACHING THE SOFT COVER

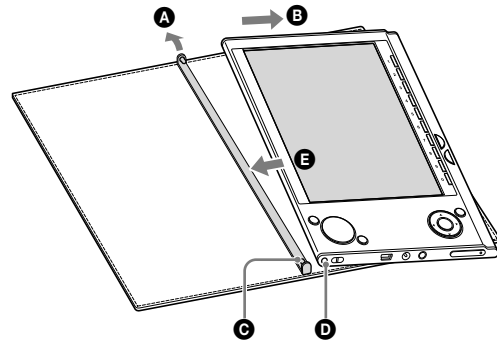

• *Removing the soft cover*

- ① Pull the tab of soft cover towards **A** .
- ② Remove Sony's Reader in the direction of **B** .

• *Attaching the soft cover*

- ① Insert the tab **C** of the soft cover in the hole **D** of Sony's Reader.
- ② Pull the tab of the soft cover towards **A** .
- ③ Insert Sony's Reader in the direction of **E** to attach it to the soft cover.
- ④ Check that the tabs of the soft cover are completely inserted in the holes of Sony's Reader.

Note: Note that the tab of the soft cover may become deformed, if you strongly pull the tab too much.

Guide to Parts and Controls

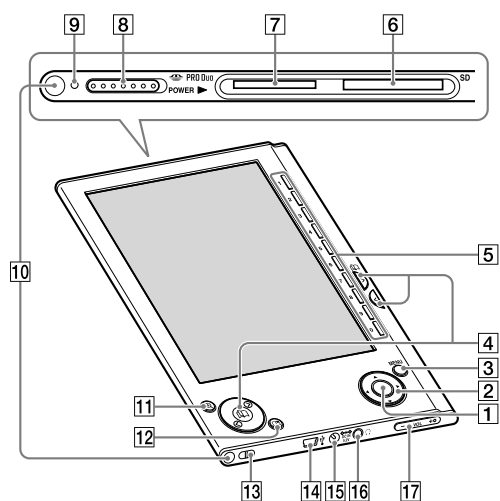

Front

- 1 Enter button*1**
To decide an item or apply a setting, press the Enter button. 
- 2 ◀/▲/▼/▶ buttons*1**
To select an item or scroll around the screen, press ◀ (left), ▲ (up), ▼ (down), or ▶ (right).
- *1 In this manual, the operation of the ◀/▲/▼/▶/Enter buttons are explained as follows.
(Example) Press ◀/▲/▼/▶ to select "Away" on the Book list, then press Enter.
- 3 MENU button**
To return to the previous screen or show a menu.
- 4 (page) / (> / <) buttons**
To turn the page or proceed/return to the next (>) / previous (<) content.
- 5 Number (1 – 9,0) buttons**
To select the numbered items on the screen or input numeric values on the Setting menu.
- 6 SD Memory Card slot**
To insert a SD Memory Card (optional).
- 7 "Memory Stick Duo" slot**
To insert a "Memory Stick Duo" (optional).
- 8 POWER switch**
To switch on/off the Reader.
- 9 Indicator**
Lights up in red while charging, and goes off when charging is complete.
Flashes in orange while the Reader is accessing your computer via USB.
Also flashes in orange while switching the Reader on or off.

- 10 Holes for soft cover attachment**
The soft cover is attached when purchased.
Folds open in use

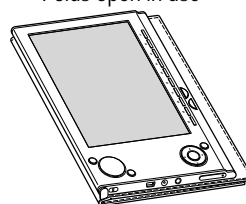

Note

- Do not leave the Reader in a high temperature conditions, as it may damage the soft cover.

- 11 (size) button**
To zoom in/out a page or picture.
- 12 (MARK) button**
To create/remove a bookmark.
- 13 Hole for hand strap**
To attach the hand strap.
- 14 USB connector**
To connect the USB cable (supplied).
- 15 DC IN jack**
To connect the AC power adapter (optional).
- Hint**
 - The Reader can be charged by connecting to a computer using the supplied USB cable.
- 16 (Headphones) jack**
To connect headphones (optional).
- 17 VOLUME +/- buttons**
To adjust the volume.
To mute the sound, press and hold the VOLUME +/- buttons. To restore the sound, press the VOLUME +/- buttons again.

Rear

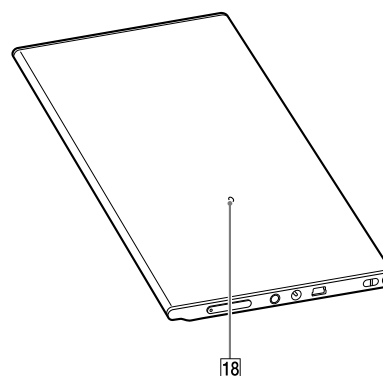

- 18 Reset button**
To reset the Reader if no operation is possible.

SECTION 3 DISASSEMBLY

- This set can be disassembled in the order shown below.

3-1. DISASSEMBLY FLOW

Note 1: The process described in [] can be performed in any order.

Note 2: Without completing the process described in [], the next process can not be performed.

Note 3: Please refer to SERVICING NOTES "REMOVING/ATTACHING THE SOFT COVER" (page 4).

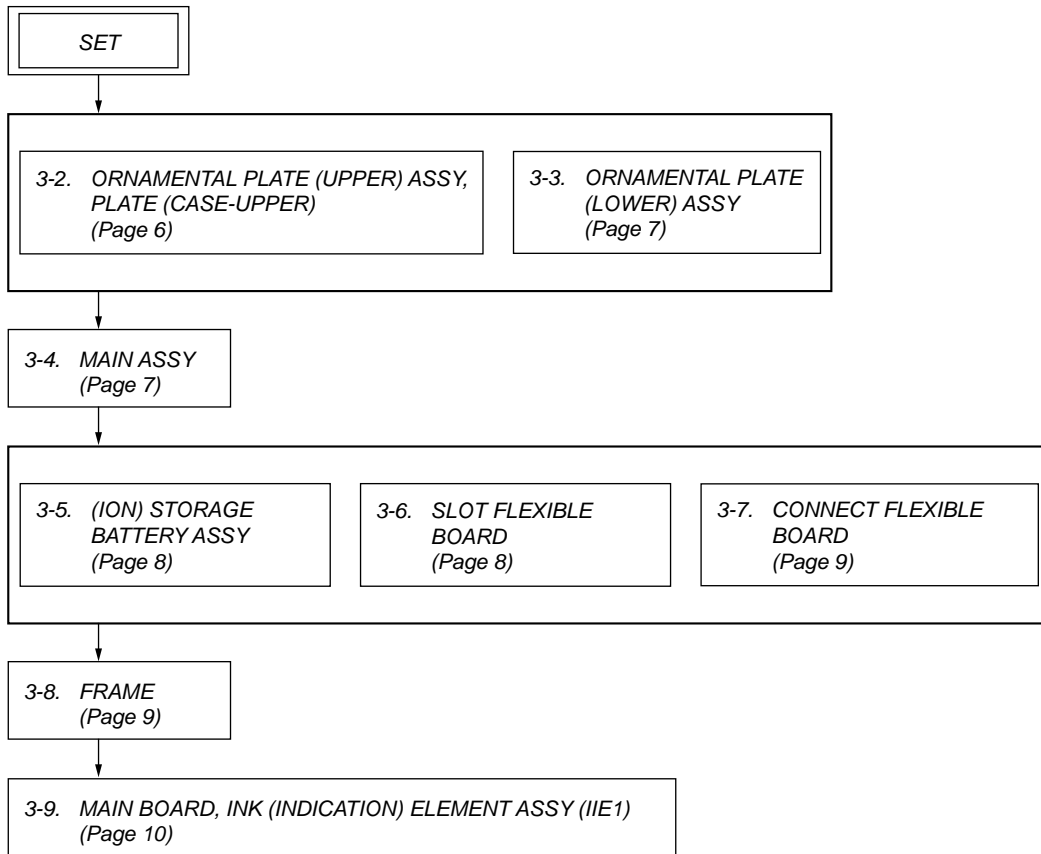

Note: Follow the disassembly procedure in the numerical order shown below.

3-2. ORNAMENTAL PLATE (UPPER) ASSY, PLATE (CASE_UPPER)

Note: When peeling off adhesive sheet, be sure to exchange it for new adhesive sheet.

- ③ Remove while moving ornamental plate (upper) assy in the direction of the arrow.

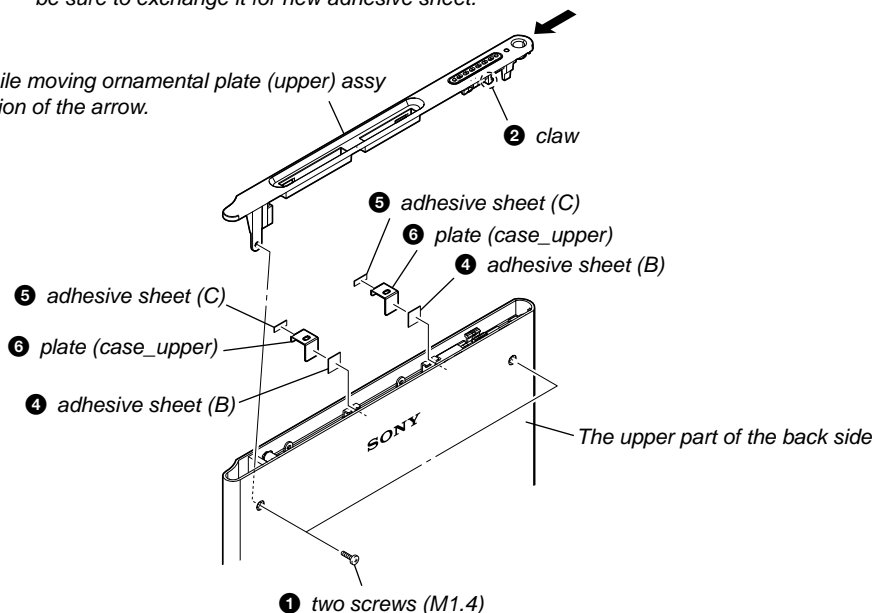

3-3. ORNAMENTAL PLATE (LOWER) ASSY

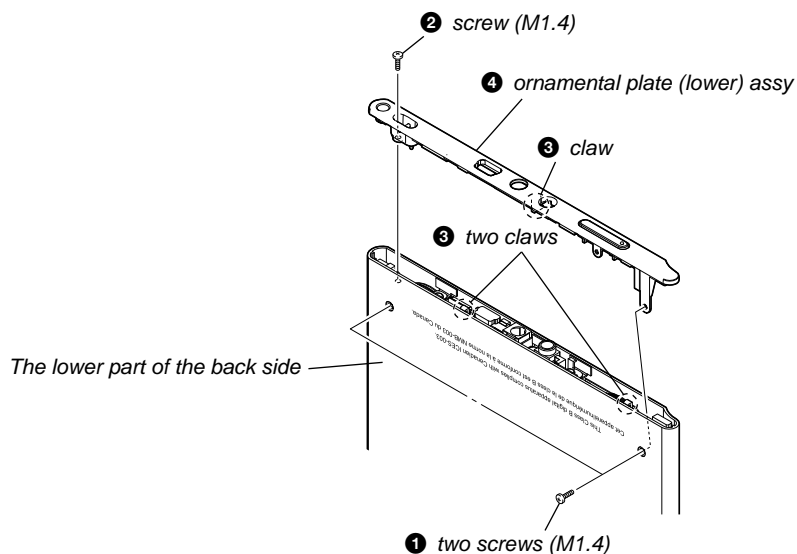

3-4. MAIN ASSY

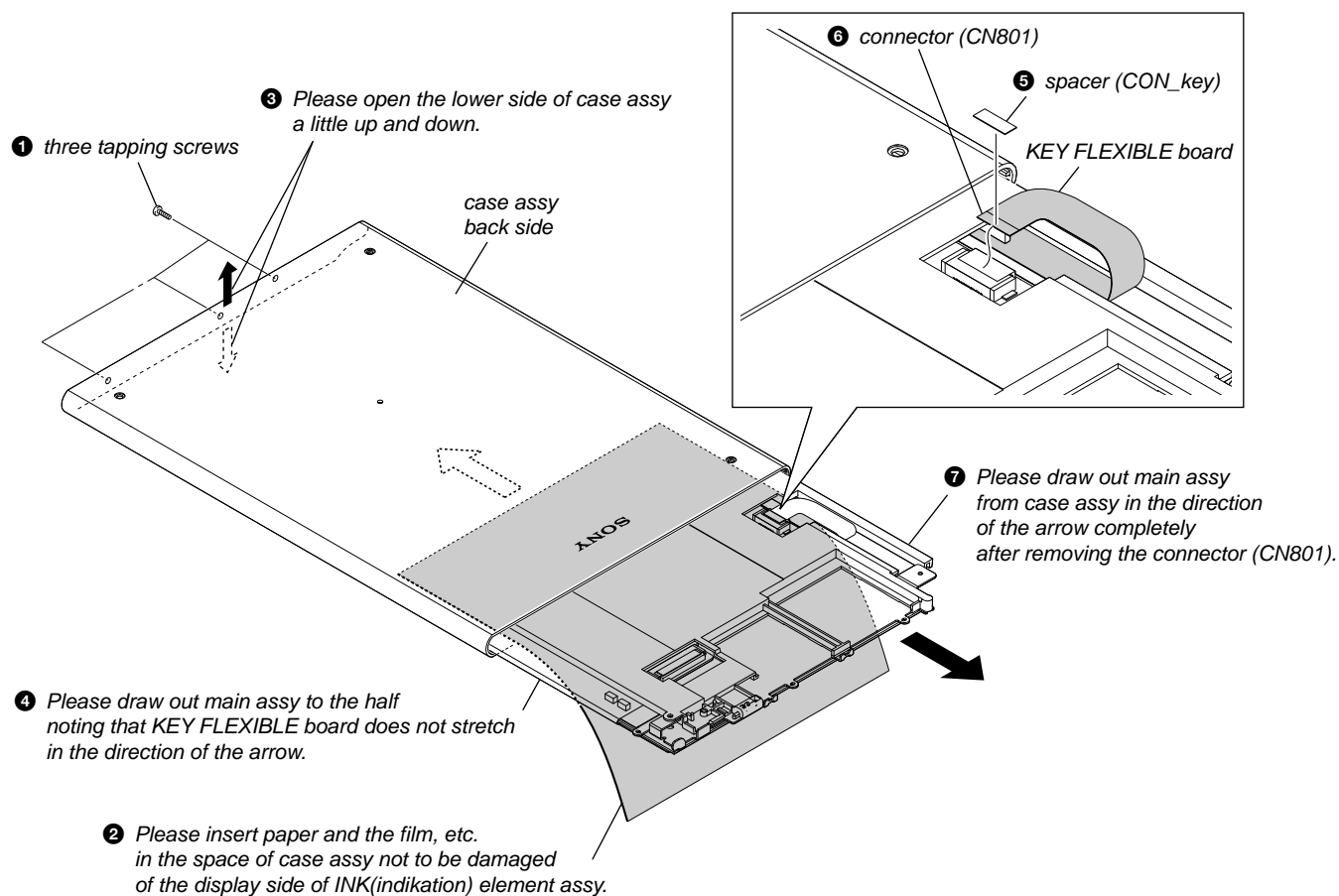

3-5. (ION) STORAGE BATTERY ASSY

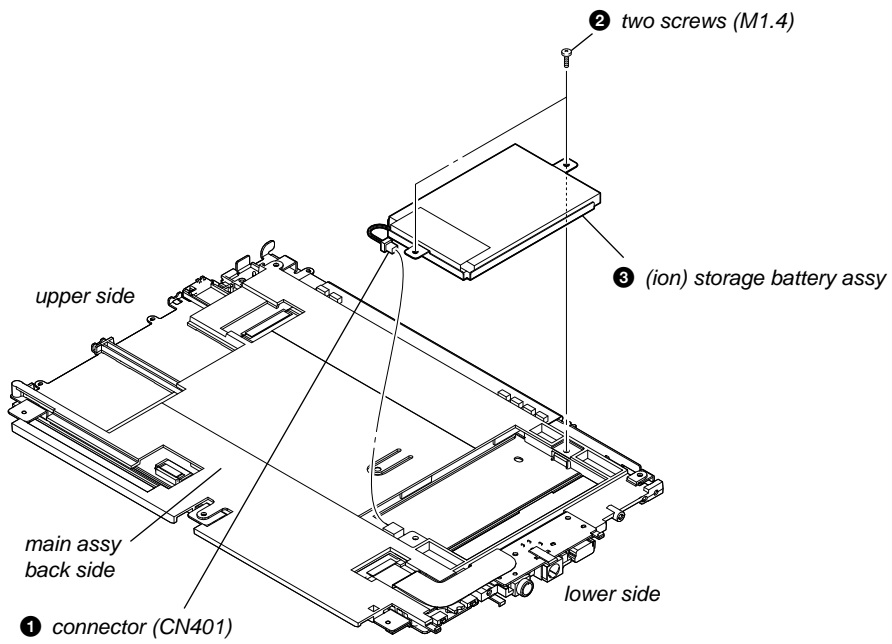

3-6. SLOT FLEXIBLE BOARD

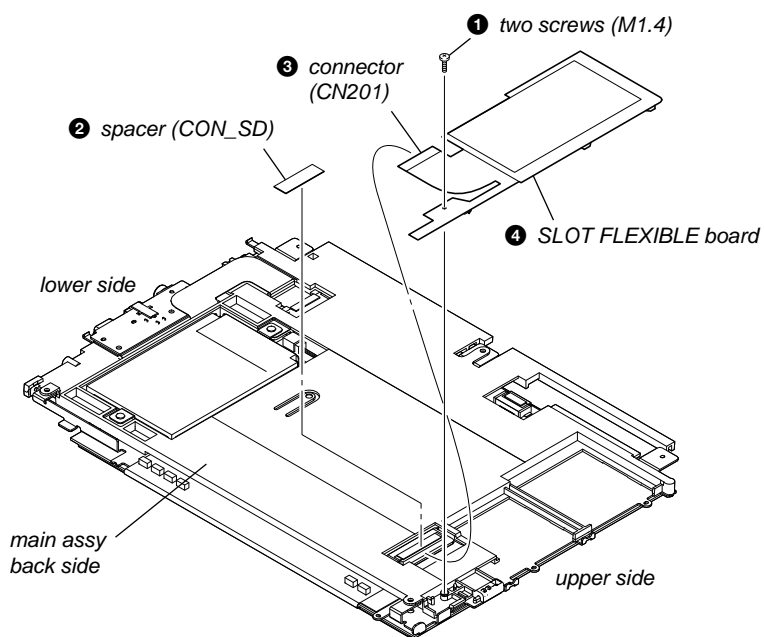

3-7. CONNECT FLEXIBLE BOARD

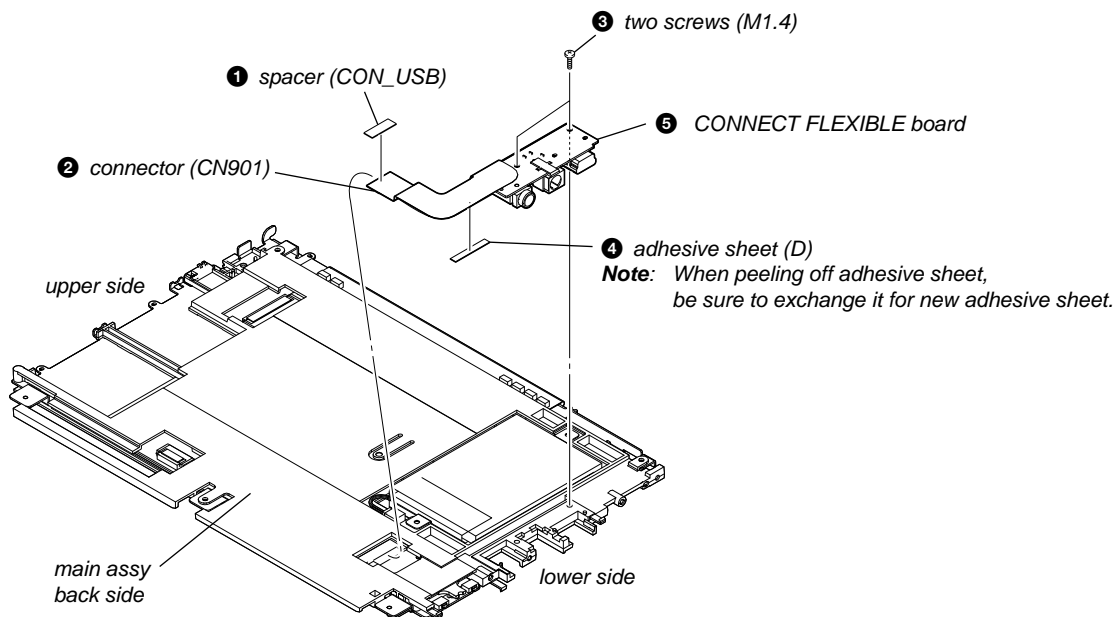

3-8. FRAME

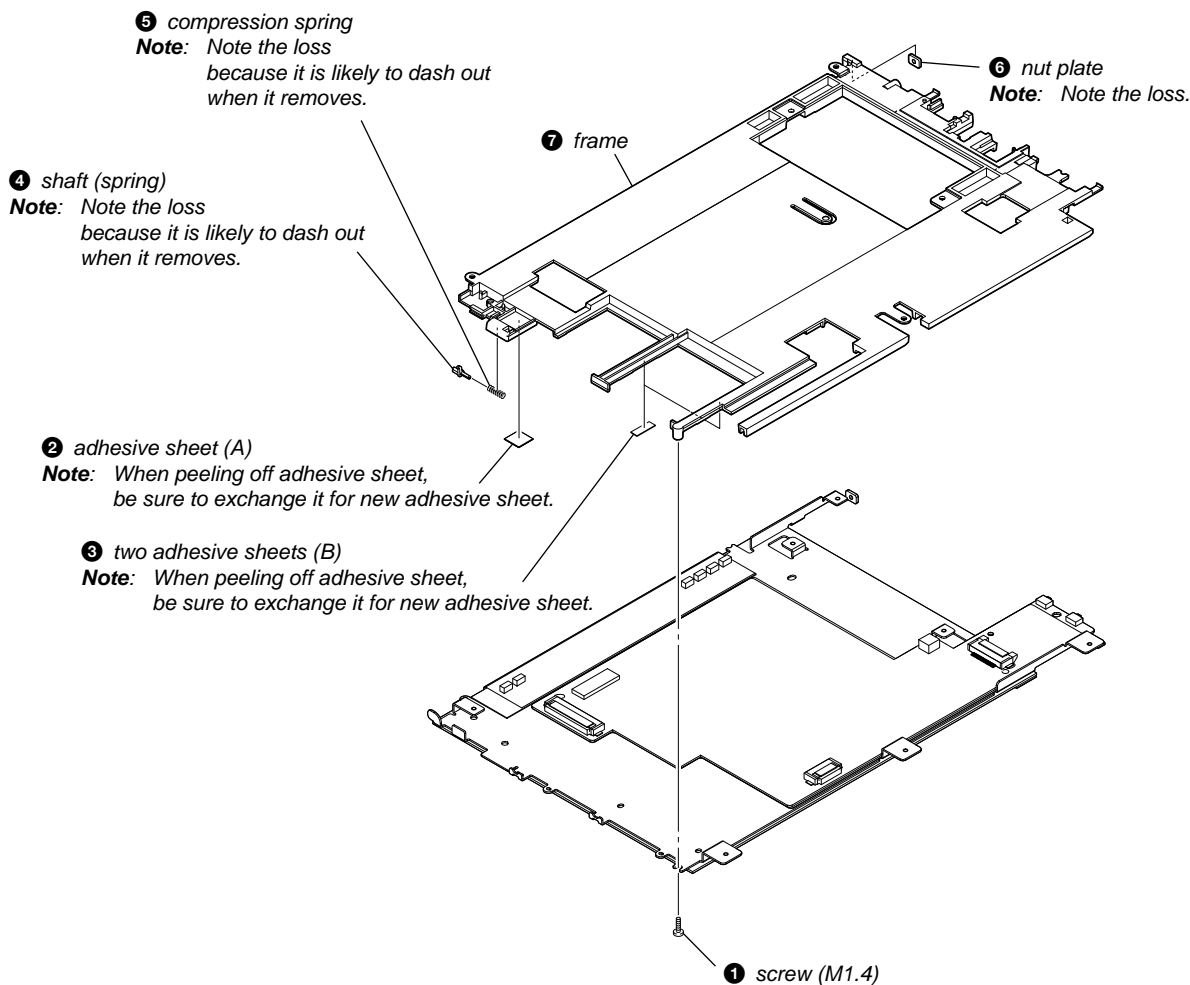

3-9. MAIN BOARD, INK (INDICATION) ELEMENT ASSY (IIE1)

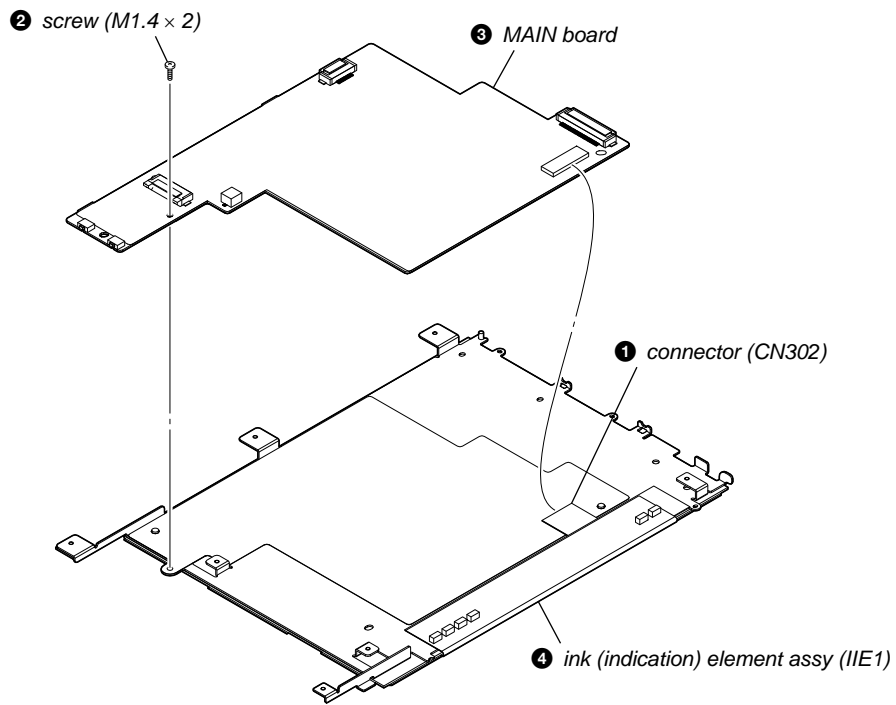

SECTION 4 TEST MODE

HOW TO MAKE THE SD MEMORY CARD OR MEMORY STICK FOR TEST MODE USE ONLY

1. Ready for the SD memory card or memory stick.
2. Make the new directly as “/Sony Reader/software” on the SD memory card or memory stick.
3. Download the as follow as the files from internet site, copy to directly.
Download files:
autorun.xml,
icon.png,
key.png,
lut.bin (If this download file’s name is different, change to this name.)

HOW TO ENTER THE TEST MODE

1. Insert the test mode SD memory card or memory stick.
2. After a while, indicate the test mode menu, enter the test mode.

1. Test Panel

1. While the machine selected tab “Test Panel” in test mode menu, press the [ENTER] button or [1] button.
2. Screen is changed to the Test Panel.
3. The display is changed so bellow with each time of pushing the [>] button or [<] button of [PAGE].

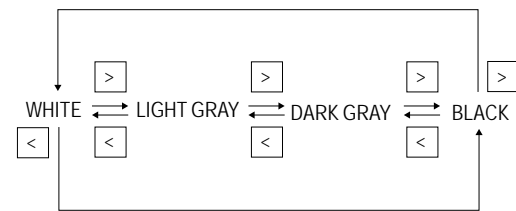

4. It's back to TEST MODE MENU when the [MENU] button.
5. After the end of test, a display of Test Panel on TEST MODE MENU is changed to “Done” from “Not Yet”.

2. Check All Key

1. In the state that a Check All Key tab of TEST MODE MENU is selected, press the [ENTER] button or [2] button.
2. The screen is switched into the Check All Key state.

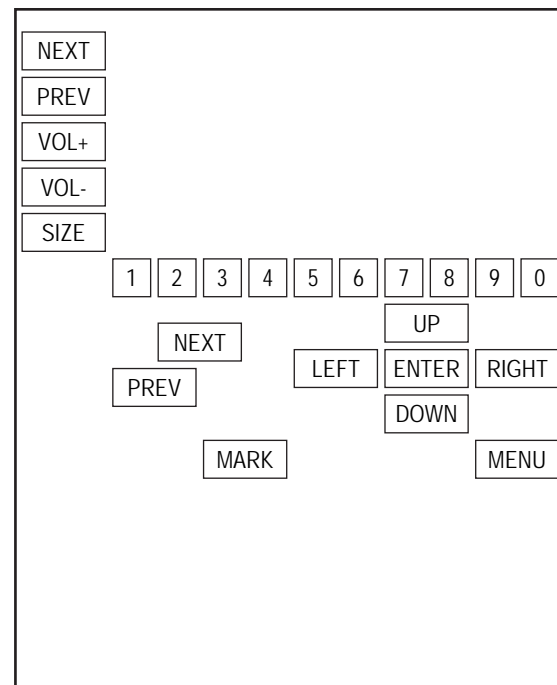

3. The display invert when each button is pushed, and the display is back to the all button.
4. After the end of test, a display of the right side of Test Panel on TEST MODE MENU is changed to “Done” from “Not Yet”.

3. Update Waveform

In this mode, it is possible to confirm the variation of LUT (Look Up Table) and rewrite. The change of the LUT is required when a INK INDICATOR ELEMENT, MAIN BOARD and FLASH ROM (IC1203) are replaced. However, a INK INDICATOR ELEMENT is different from parameter by each lot number, therefore, rewriting is not required if the lot number is the same. The lot number is written on the label on the flexible board.

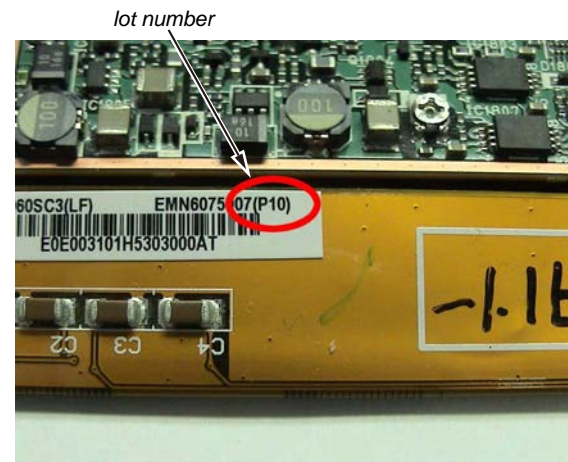

1. The current LUT version displayed at the right side of Update Waveform on TEST MODE MENU.
2. In the state that a Update Waveform tab is selected if it is press the [ENTER] button or [3] button, it starts rewriting LUT version.

Note: It is necessary to match the LUT version to the version in relation to the lot number of the INK INDICATOR ELEMENT. Refer to Technical News about details.

3. After a few minutes (about 10 seconds), the screen display is refreshed, a LUT version display of the right side of Update Waveform on TEST MODE MENU is refreshed.

4. Reset Screen Lock

The screen lock can be compulsorily released.

1. The current state of screen lock and the password are displayed on the right side of Reset Screen Lock of TEST MODE MENU.
2. In the state that the Reset Screen Lock tab of TEST MODE MENU is selected, press the [ENTER] button or [4] button.
3. The display on the right side of Reset Screen Lock is changed to “Off-0000”, so Screen Lock is unlocked .

5. Power Off

1. In the state of a Power Off tab of TEST MODE MENU, press the [ENTER] button or [5] button.
2. After a while, the screen display is changed white, so power is turned off.

6. Factory Initialize

It return to the state various setting are shipped in the factory. The file of Flash ROM deletes all files except file the factory is shipped. Please note it enough you operate this mode.

1. In the state of a Factory Initialize tab of TEST MODE MENU, press the [ENTER] button or [6] button.
2. Initialize end. After a while, the screen display is changed white, so power is turned off.

SECTION 5 ELECTRICAL ADJUSTMENT

VCOM VOLTAGE ADJUSTMENT

Vcom voltage for the display panel varies for each panel. VCOM adjustment is required when replacing a board or panel.

Preparation:

Voltage is generated only when the screen is changed, so the adjustment needs to be performed while changing the screen. Use the slideshow function to change the screen sequentially.

1. With the “Settings” tab in the menu selected, press the [ENTER] button or the [0] button.
2. With the “Slideshow” tab selected, press the [ENTER] button or the [3] button.
3. Set “Turn On, Slide Duration 05 seconds”, and press the [ENTER] button on OK.

Procedure:

1. With the “Pictures” tab in the menu selected, press the [ENTER] button or the [9] button.
2. Specify a desired screen, and press the [ENTER] button to check that the slideshow starts.
3. Observe the TP354 on an oscilloscope (refer to Fig.2), and use RV1801 to adjust the voltage that is generated when the screen is changed so that it satisfies the standard.

Standard: Written on the flexible card wire of the display panel with a marker. (-1 V to -2.5 V) (Refer to following Fig.1)
(In case of Fig.1: The value of VCOM is -1.16 V.)



Fig. 1

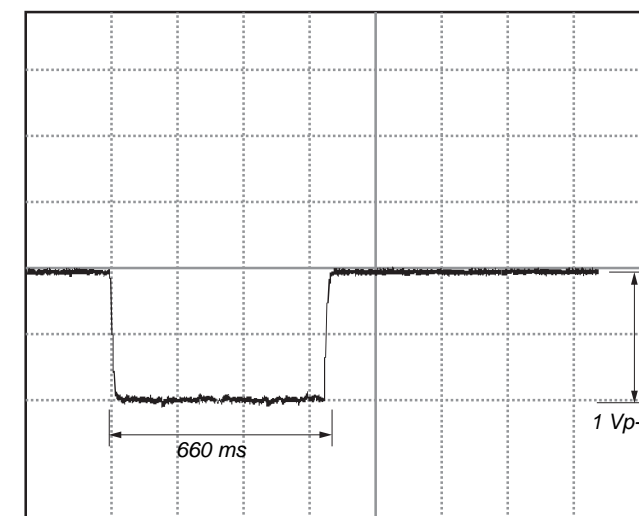

500 mV/DIV, 200 ms/DIV

Fig. 2

Adjustment Location:

- MAIN Board (Component Side) -

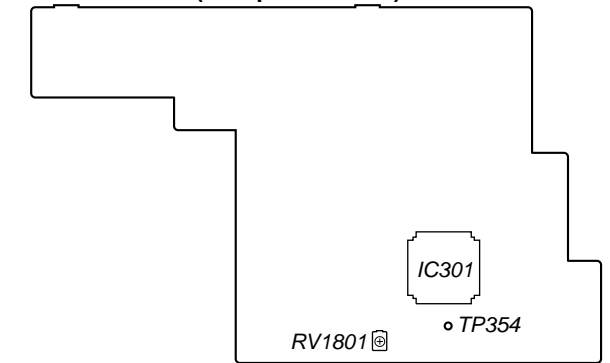

SECTION 6
DIAGRAMS

6-1. BLOCK DIAGRAM - MAIN Section (1/2) -

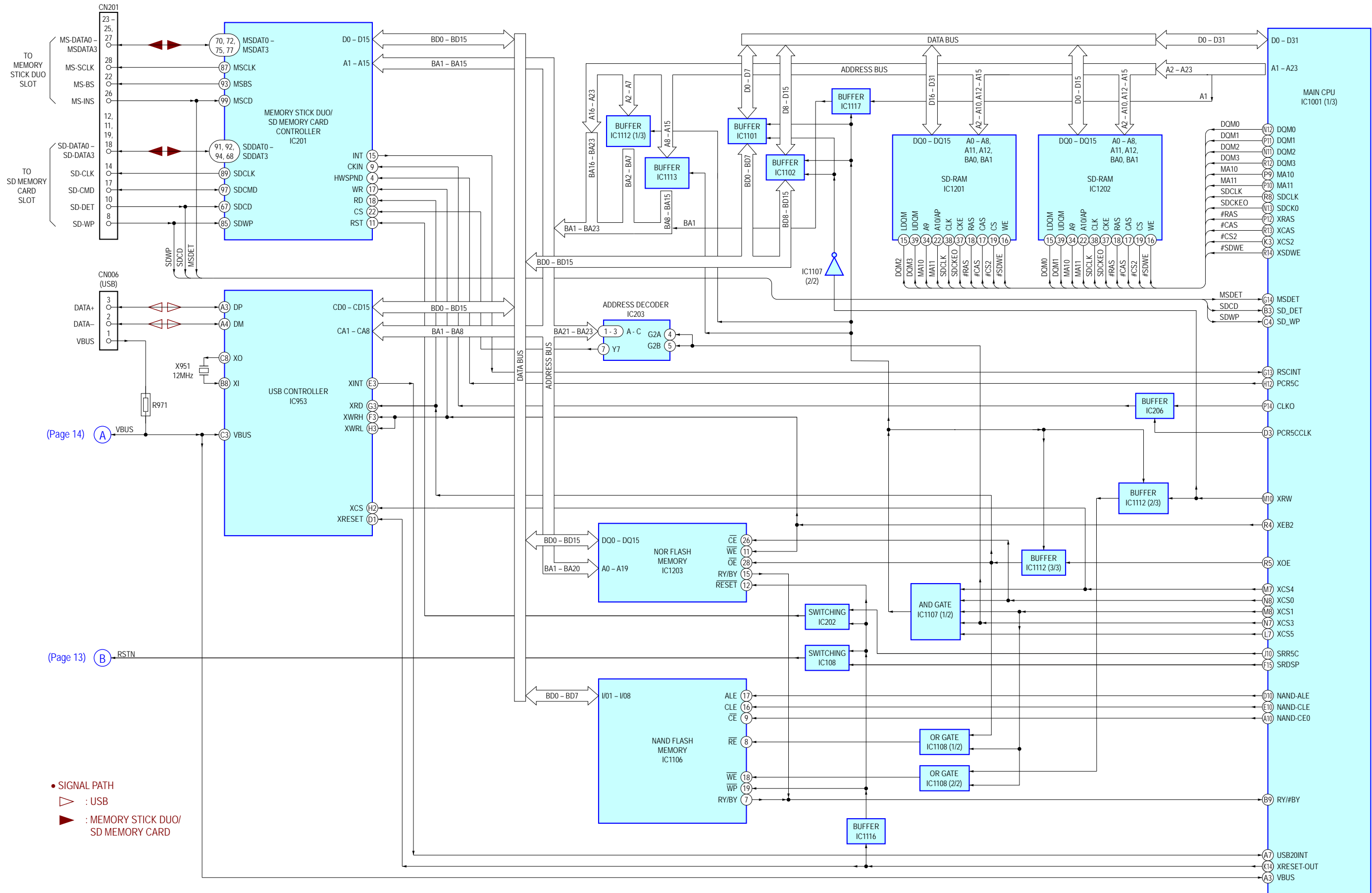

(Page 14) A

(Page 13) B

• SIGNAL PATH
▶ : USB
▶ : MEMORY STICK DUO/
 SD MEMORY CARD

6-2. BLOCK DIAGRAM - MAIN Section (2/2) -

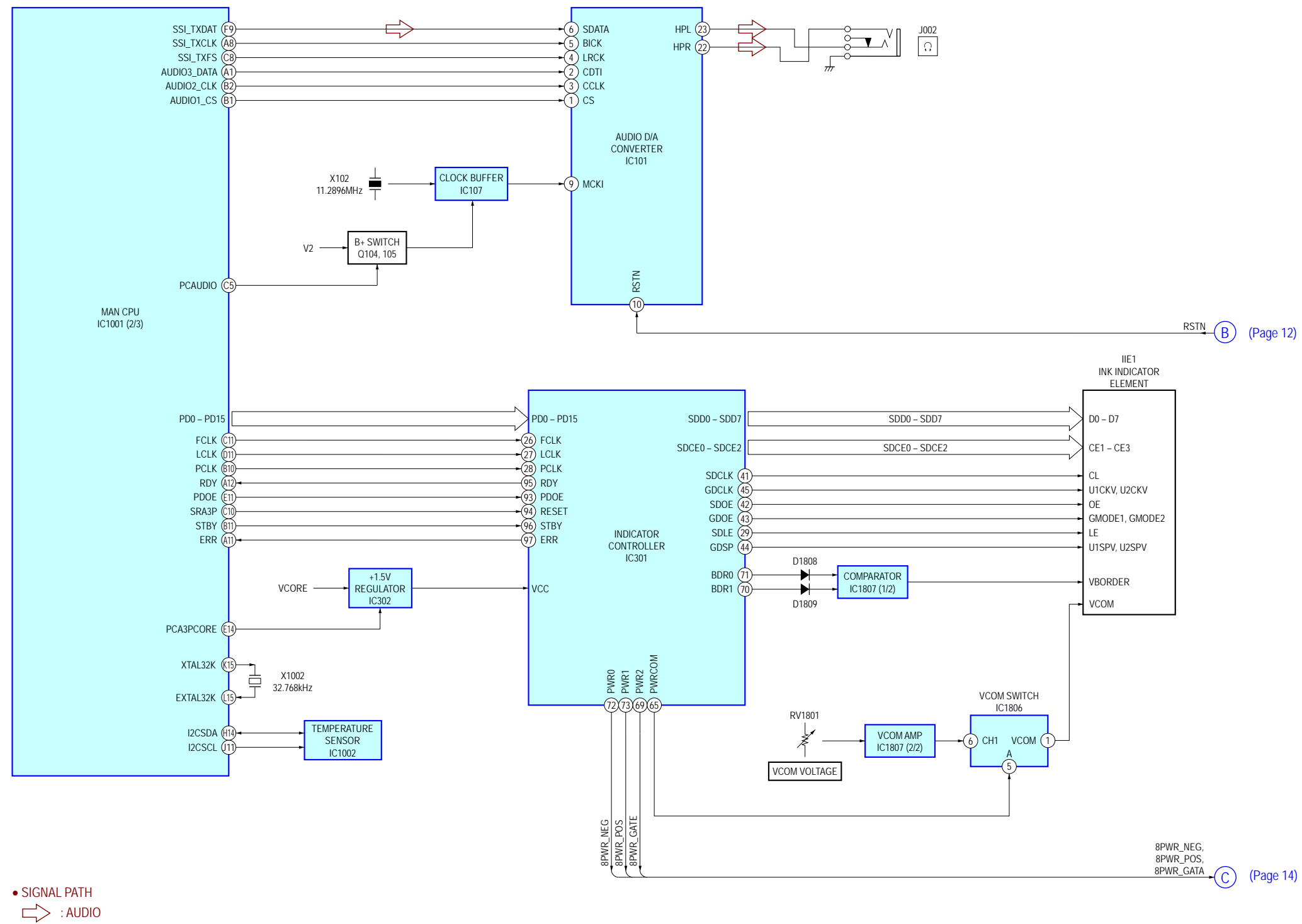

6-3. BLOCK DIAGRAM - KEY/POWER SUPPLY Section -

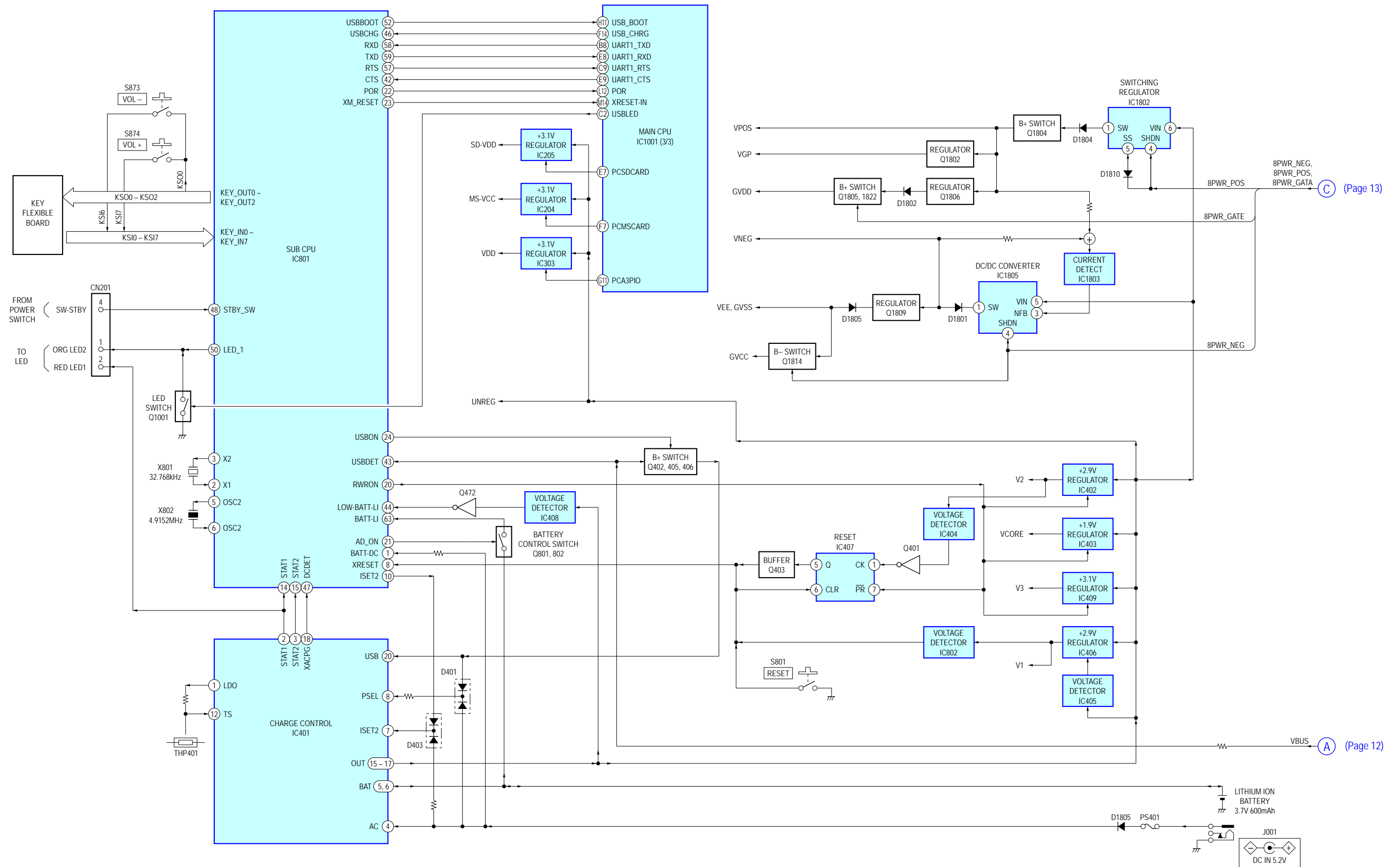

THIS NOTE IS COMMON FOR PRINTED WIRING BOARDS AND SCHEMATIC DIAGRAMS.
(In addition to this, the necessary note is printed in each block.)

For Printed Wiring Boards.

Note:

- : Parts extracted from the conductor side.
- △ : internal component.
- : Pattern from the side which enables seeing.
 (The other layers' patterns are not indicated.)

Caution:

Parts face side: Parts on the parts face side seen from
 (Conductor side) the pattern face are indicated.
 Pattern face side: Parts on the pattern face side seen from
 (Component side) the parts face are indicated.

- MAIN board is multi-layer printed board.
 However, the patterns of intermediate-layers have not been included in diagrams.

* Replacing of IC1001 on the MAIN board used in this set requires a special tool.

- Lead layouts

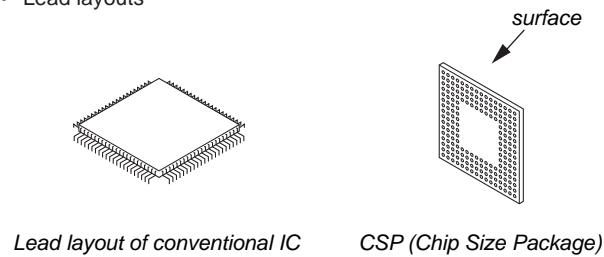

For Schematic Diagrams.

Note:

- All capacitors are in μF unless otherwise noted. (p: pF)
 50 WV or less are not indicated except for electrolytics and tantalums.
- All resistors are in Ω and $1/4$ W or less unless otherwise specified.
- △ : internal component.
- : panel designation.

Note:

The components identified by mark △ or dotted line with mark △ are critical for safety.
 Replace only with part number specified.

Note:

Les composants identifiés par une marque △ sont critiques pour la sécurité.
 Ne les remplacer que par une pièce portant le numéro spécifié.

- : B+ Line.
- - - : B- Line.
- : adjustment for repair.
- Power voltage is dc 5.2V and fed with regulated dc power supply from TP402 and TP400 on the MAIN board.
- Voltages and waveforms are dc with respect to ground under no-signal (detuned) conditions.
 no mark: POWER ON
 () : AUDIO PLAY
 * : Impossible to measure
 (For this model, the voltage is produced only when the screen is changed. Under the power on, there is a voltage that is not produced.)
- Voltages are taken with VOM (Input impedance 10 M Ω).
 Voltage variations may be noted due to normal production tolerances.
- Waveforms are taken with a oscilloscope.
 Voltage variations may be noted due to normal production tolerances.
- Circled numbers refer to waveforms.
- Signal path.
 ⇨ : AUDIO
 ⇨⇨ : VIDEO
 ▽ : USB
 ▾ : SD MEMORY CARD/MEMORY STICK DUO

* Replacing of IC1001 on the MAIN board used in this set requires a special tool.

- The voltage and waveform of CSP (chip size package) cannot be measured, because its lead is different from that conventional IC.

• Waveforms

– MAIN Board –

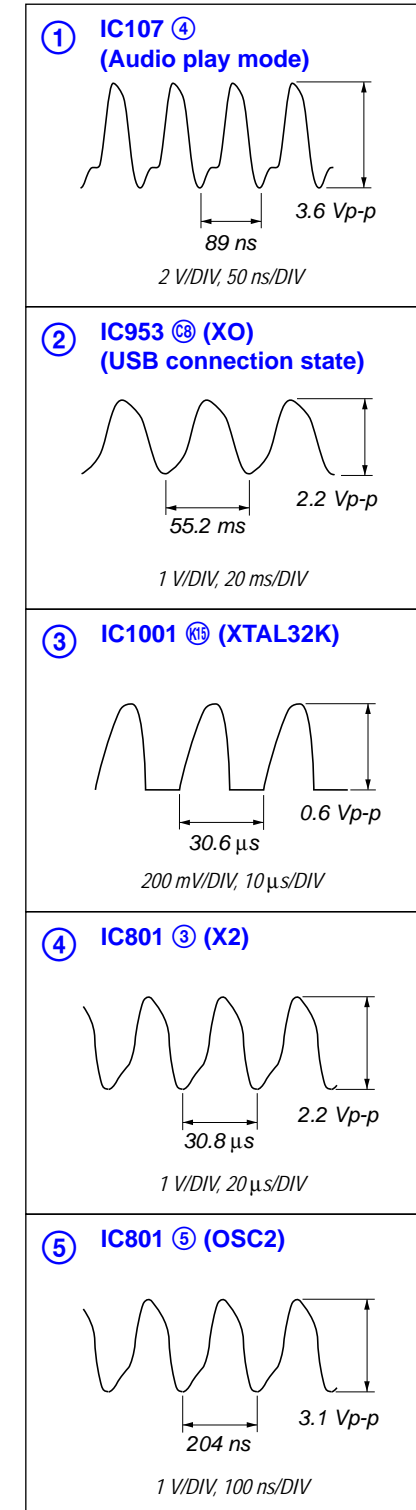

6-4. PRINTED WIRING BOARD - MAIN Board (Component Side) - • **LF** : Uses unleaded solder.

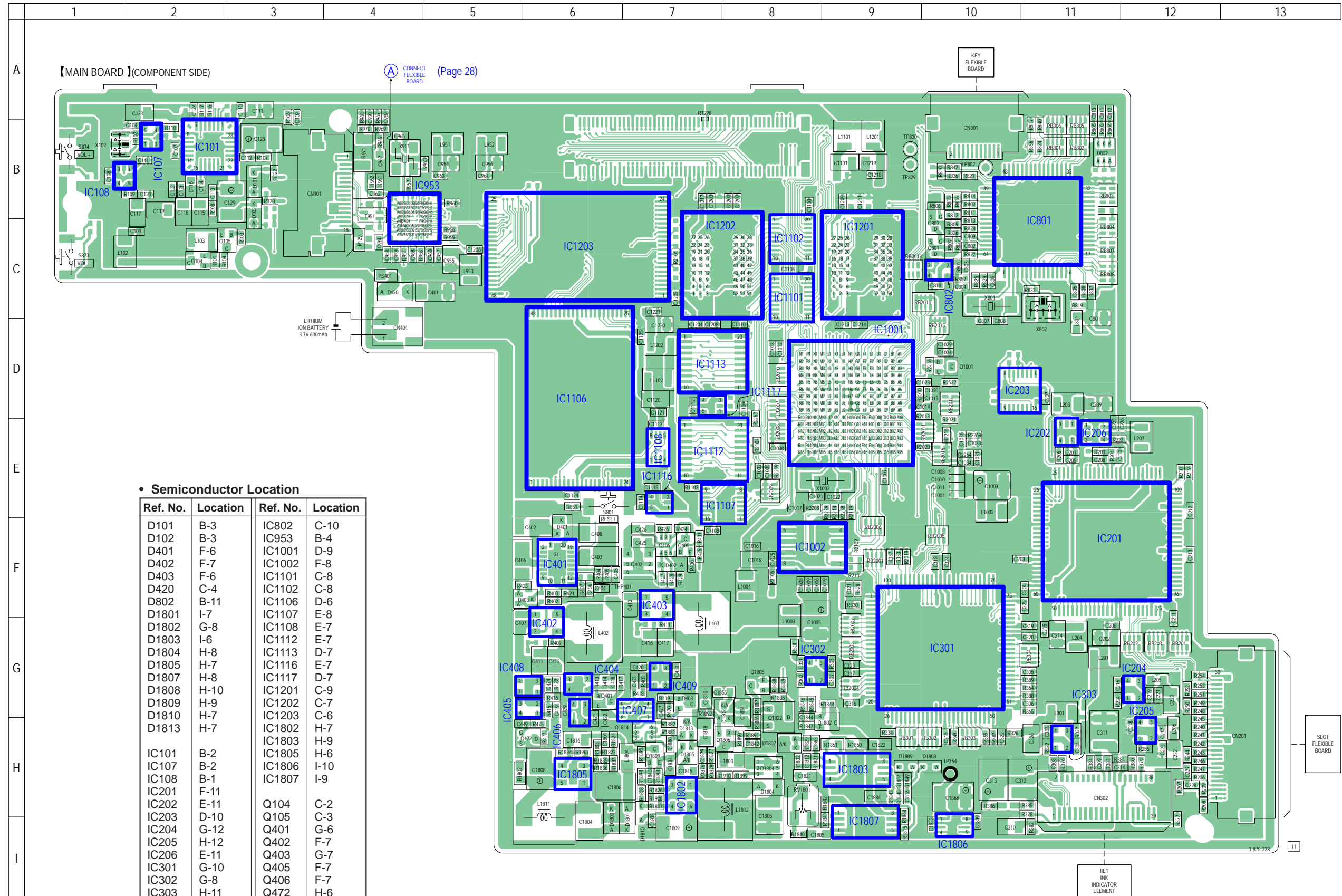

• Semiconductor Location

Ref. No.	Location	Ref. No.	Location
D101	B-3	IC802	C-10
D102	B-3	IC953	B-4
D401	F-6	IC1001	D-9
D402	F-7	IC1002	F-8
D403	F-6	IC1101	C-8
D420	C-4	IC1102	C-8
D802	B-11	IC1106	D-6
D1801	I-7	IC1107	E-8
D1802	G-8	IC1108	E-7
D1803	I-6	IC1112	E-7
D1804	H-8	IC1113	D-7
D1805	H-7	IC1116	E-7
D1807	H-8	IC1117	D-7
D1808	H-10	IC1201	C-9
D1809	H-9	IC1202	C-7
D1810	H-7	IC1203	C-6
D1813	H-7	IC1802	H-7
		IC1803	H-9
		IC1805	H-6
		IC1806	I-10
		IC1807	I-9
IC101	B-2	Q104	C-2
IC107	B-2	Q105	C-3
IC108	B-1	Q401	G-6
IC201	F-11	Q402	F-7
IC202	E-11	Q403	G-7
IC203	D-10	Q405	F-7
IC204	G-12	Q472	H-6
IC205	H-12	Q801	C-10
IC206	E-11	Q802	C-10
IC301	G-10	Q1001	D-10
IC302	G-8	Q1802	H-9
IC303	H-11	Q1804	H-8
IC401	F-6	Q1805	G-8
IC402	G-6	Q1806	H-8
IC403	F-7	Q1809	H-7
IC404	G-6	Q1814	H-7
IC405	G-6	Q1822	H-8
IC406	G-6		
IC407	G-7		
IC408	G-6		
IC409	G-7		
IC801	C-11		

Note: When IC301, IC953, IC1106, IC1201, IC1202 and IC1203 on the MAIN board is damaged, exchange the new MAIN board for the MAIN board which IC damaged.

6-5. PRINTED WIRING BOARD - MAIN Board (Conductor Side) - •  : Uses unleaded solder.

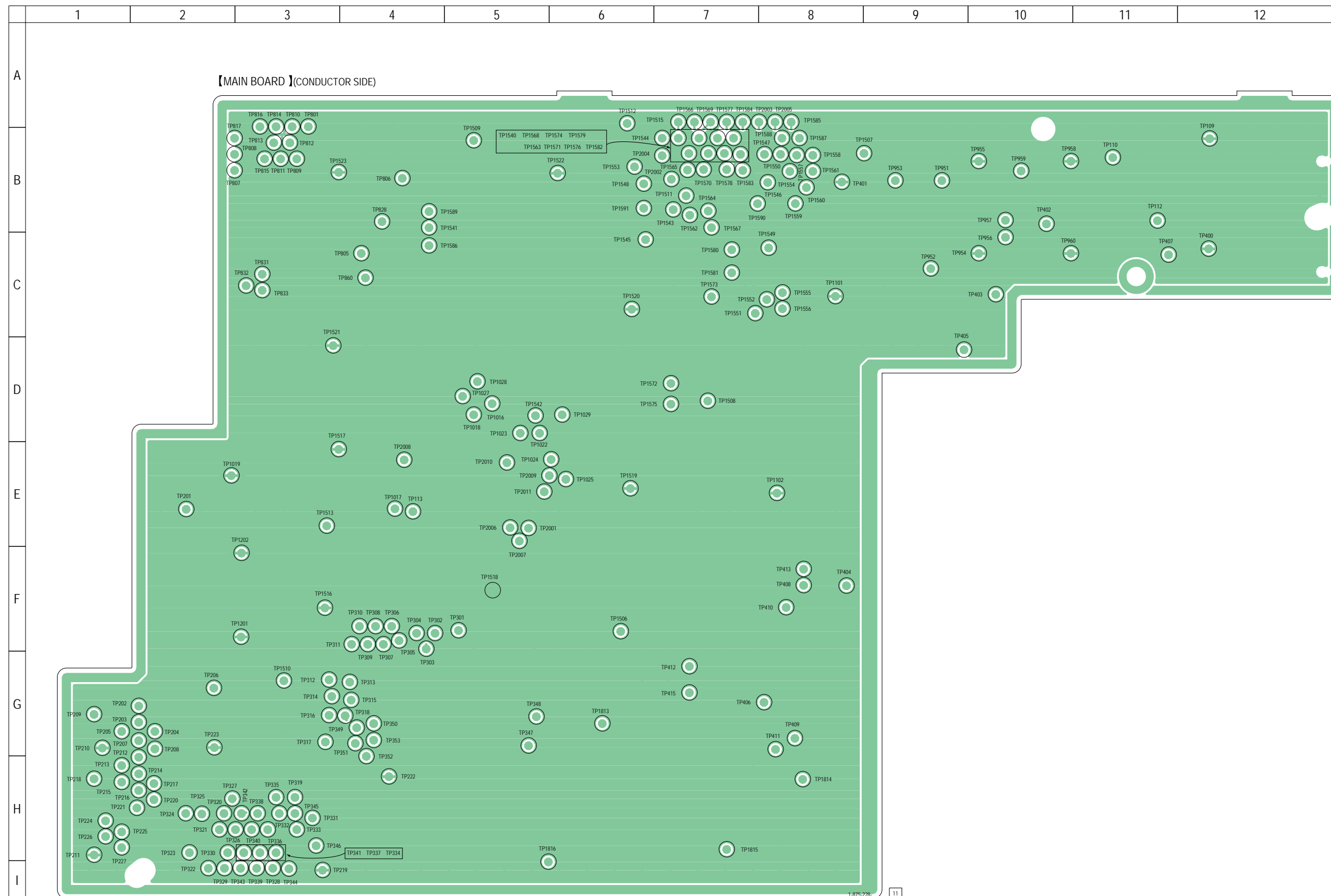

6-6. SCHEMATIC DIAGRAM - MAIN Board (1/10) - • See page 29 for IC Block Diagram. • See page 34 for IC Pin Function Description.

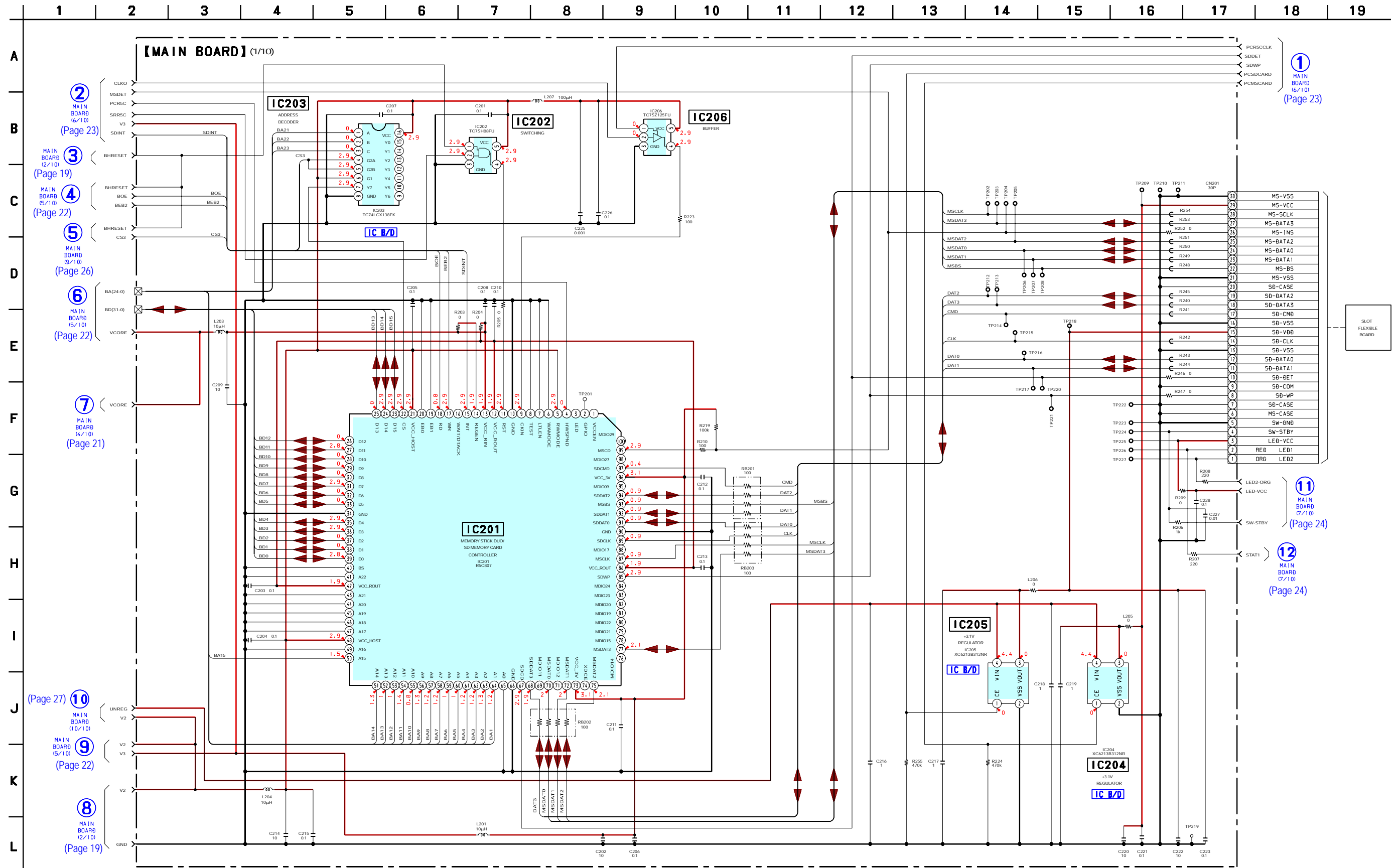

6-7. SCHEMATIC DIAGRAM - MAIN Board (2/10) - • See page 15 for waveform. • See page 29 for IC Block Diagram.

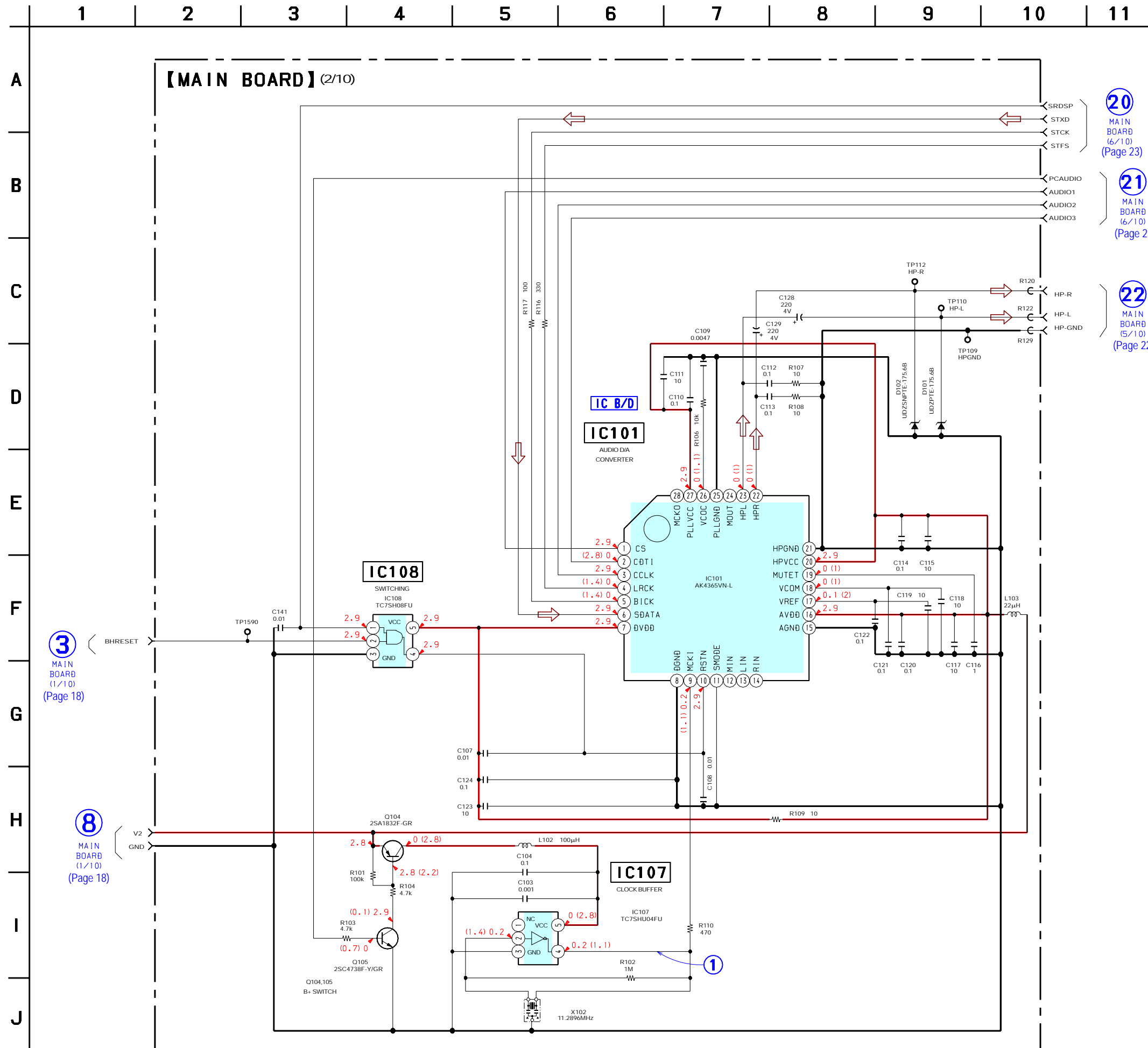

6-8. SCHEMATIC DIAGRAM - MAIN Board (3/10) - • See page 29 for IC Block Diagram.

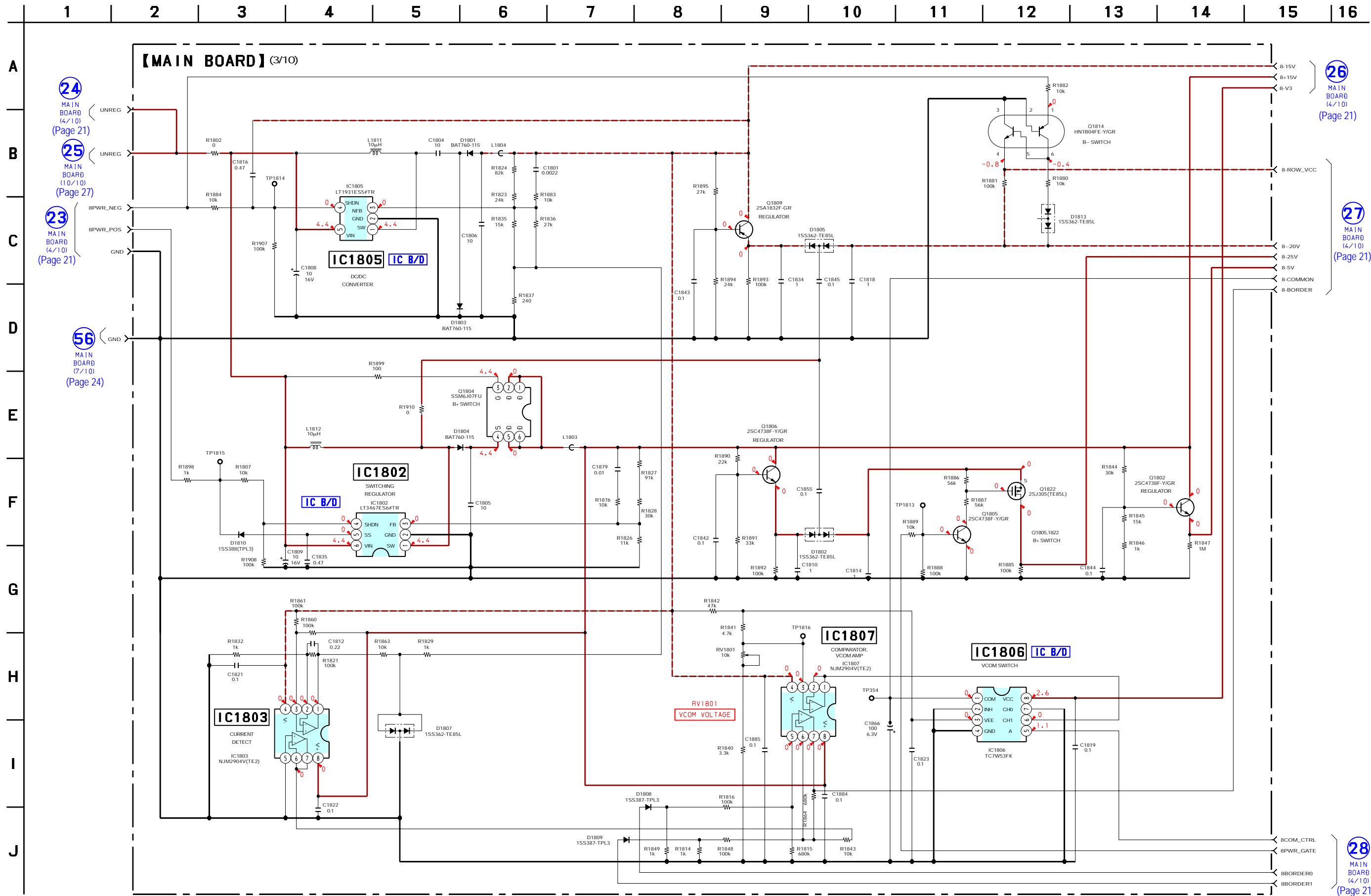

6-9. SCHEMATIC DIAGRAM - MAIN Board (4/10) - • See page 29 for IC Block Diagram. • See page 34 for IC Pin Function Description.

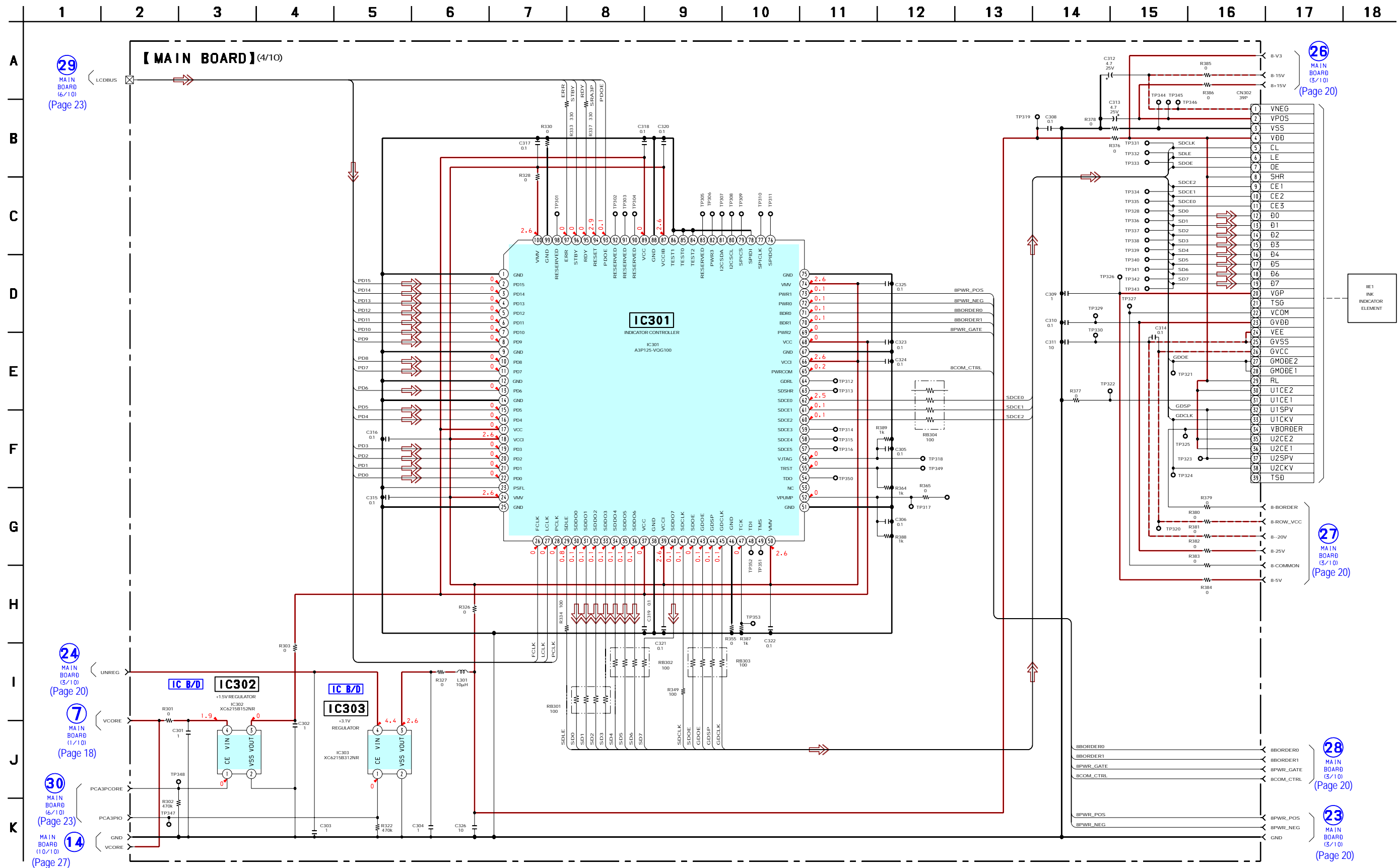

Note: When IC301 on the MAIN board is damaged, exchange the new MAIN board for the MAIN board which IC damaged.

6-11. SCHEMATIC DIAGRAM - MAIN Board (6/10) - • See page 15 for waveform. • See page 29 for IC Block Diagram. • See page 34 for IC Pin Function Description.

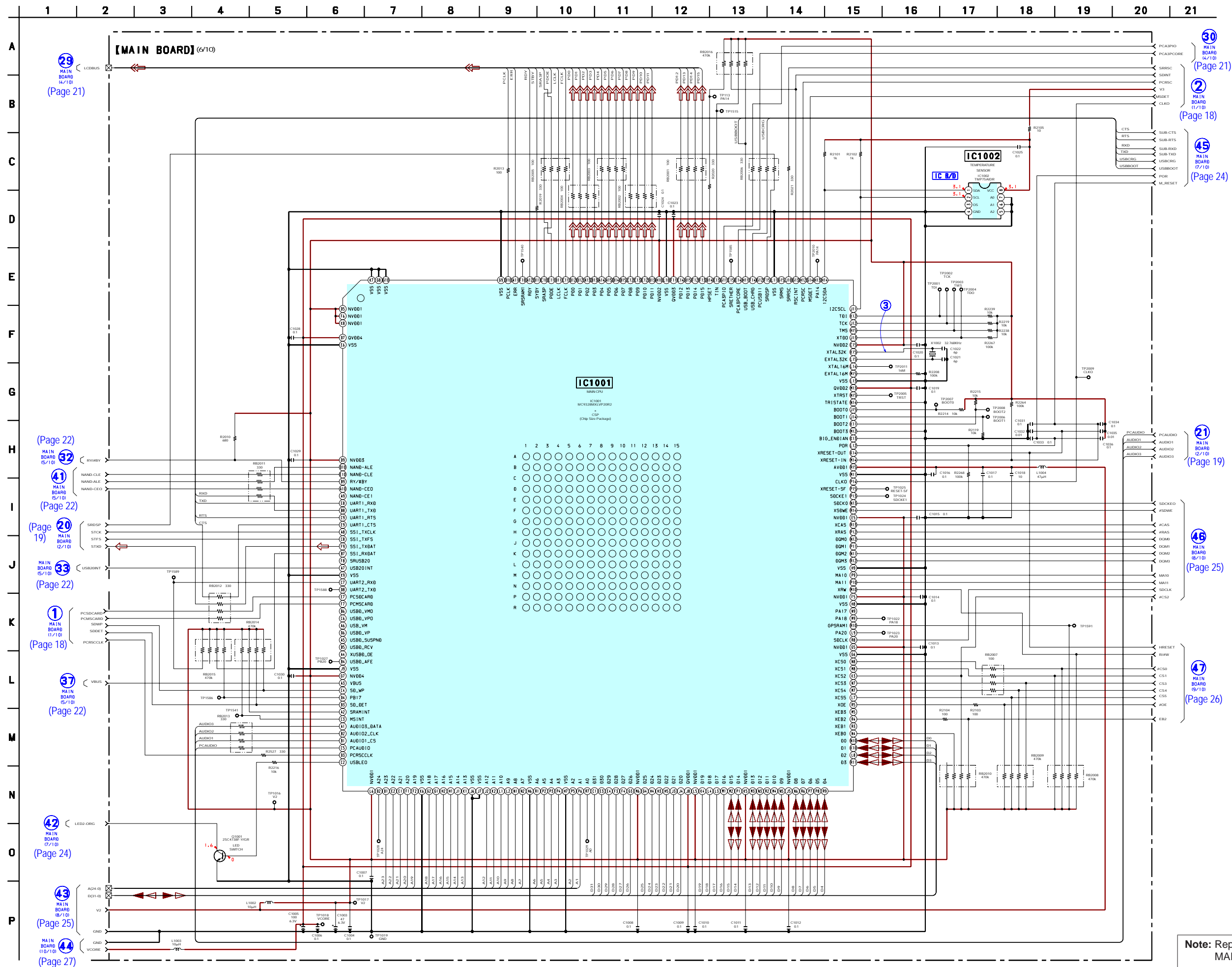

6-12. SCHEMATIC DIAGRAM - MAIN Board (7/10) - • See page 15 for waveform. • See page 34 for IC Pin Function Description.

1 2 3 4 5 6 7 8 9 10 11 12 13 14 15 16

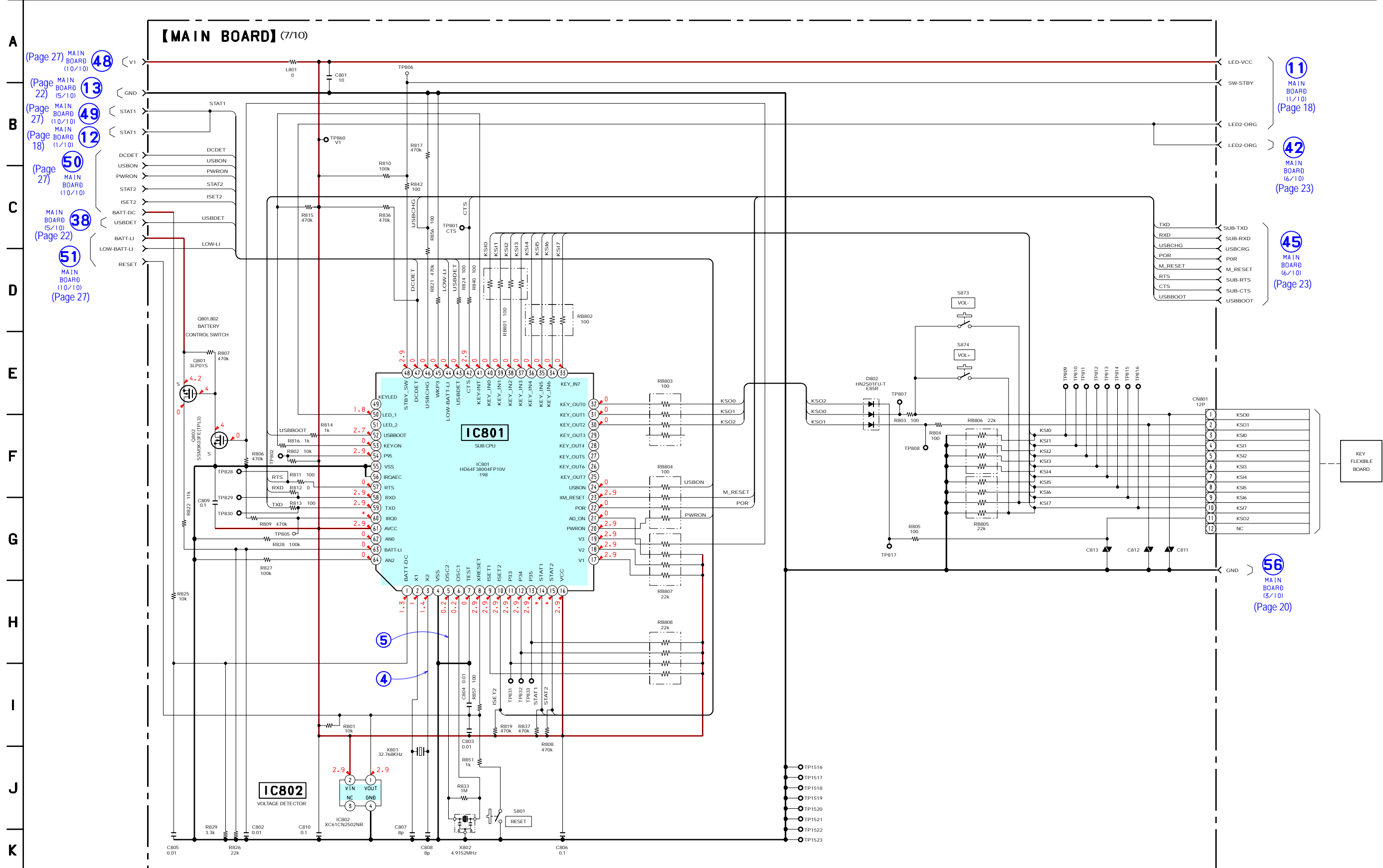

6-13. SCHEMATIC DIAGRAM - MAIN Board (8/10) -

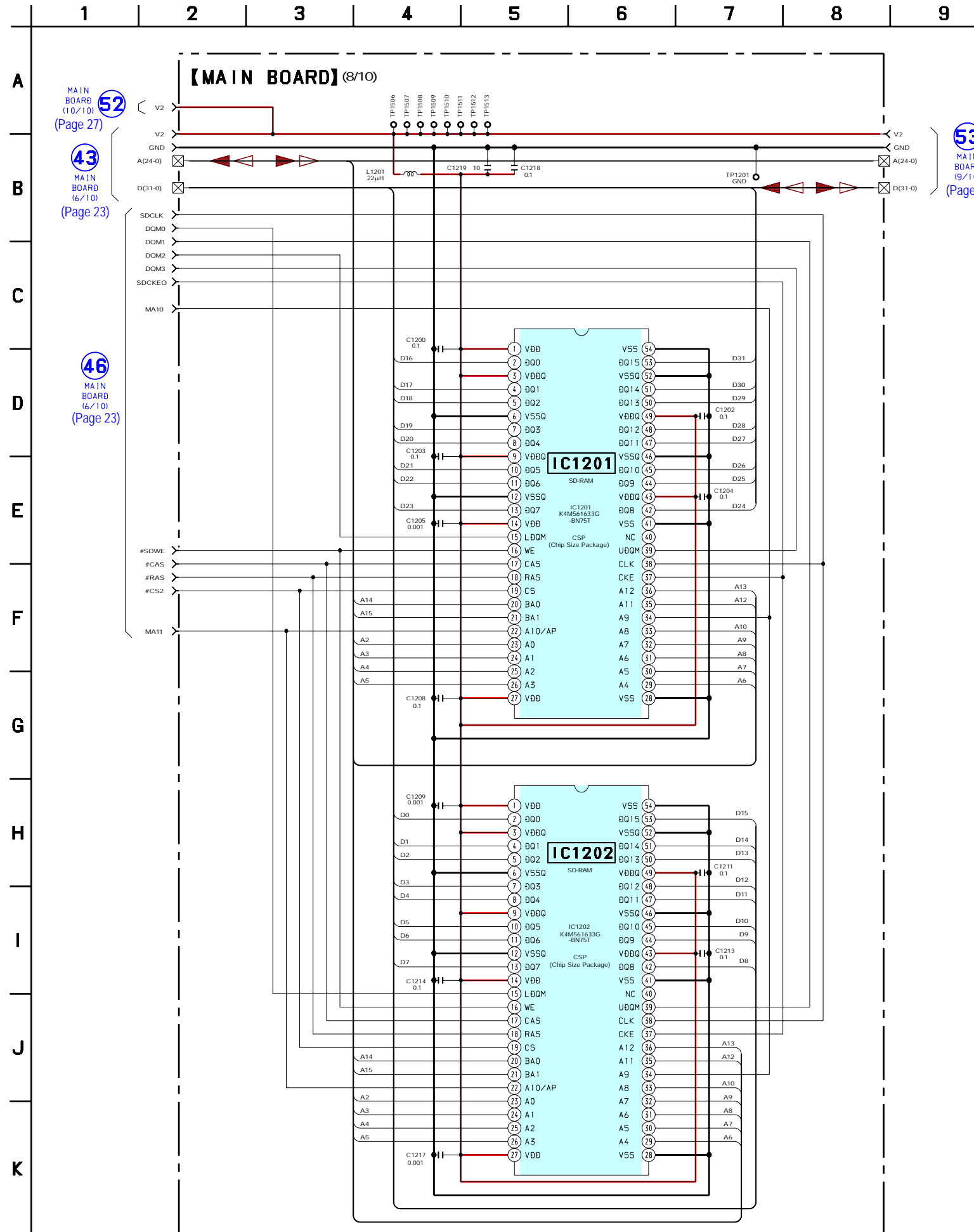

Note: When IC1201 and IC1202 on the MAIN board is damaged, exchange the new MAIN board for the MAIN board which IC damaged.

6-14. SCHEMATIC DIAGRAM - MAIN Board (9/10) - • See page 29 for IC Block Diagram.

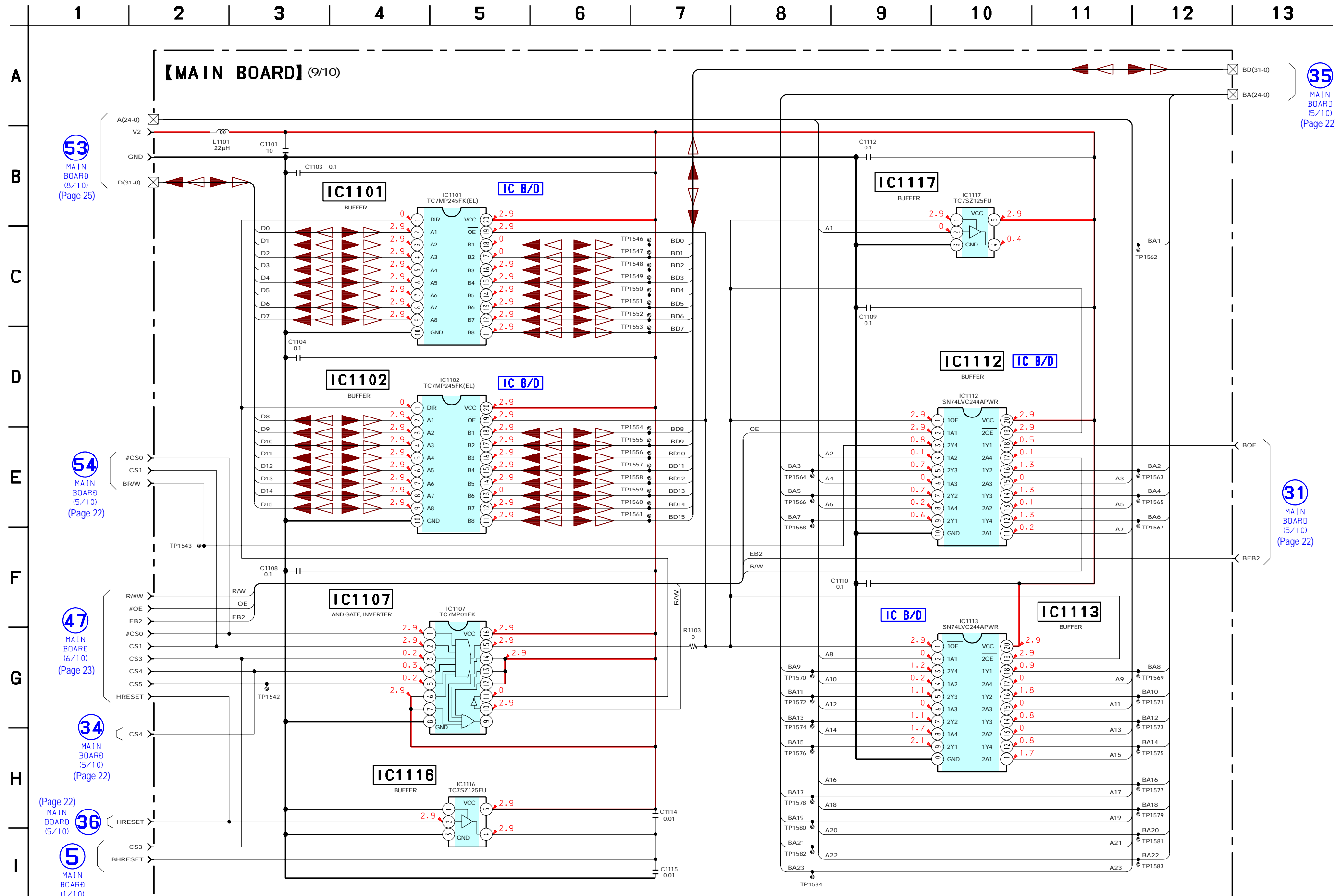

6-15. SCHEMATIC DIAGRAM - MAIN Board (10/10) - • See page 29 for IC Block Diagram. • See page 34 for IC Pin Function Description.

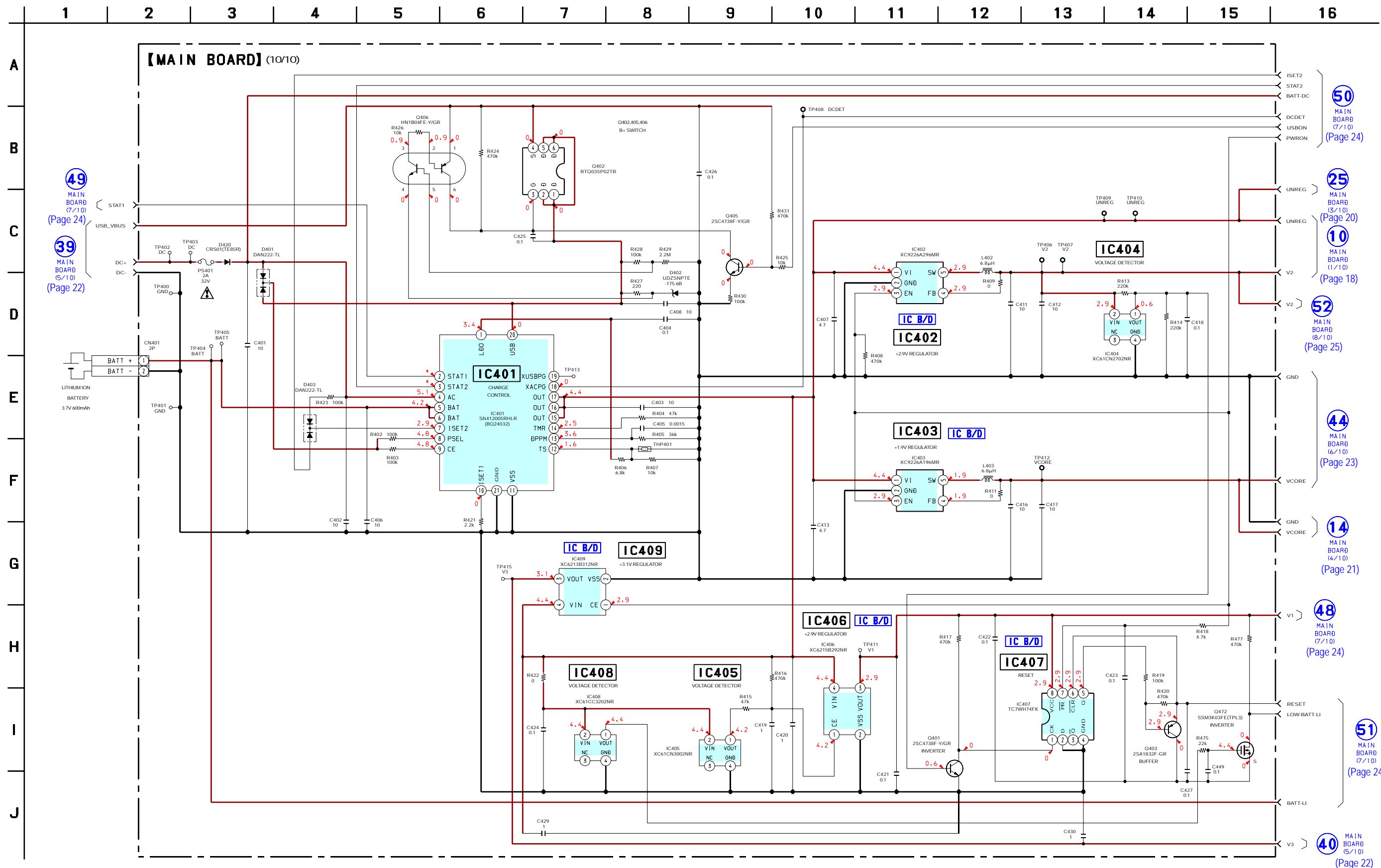

49 MAIN BOARD (7/10) (Page 24)

39 MAIN BOARD (5/10) (Page 22)

50 MAIN BOARD (7/10) (Page 24)

25 MAIN BOARD (3/10) (Page 20)

10 MAIN BOARD (1/10) (Page 18)

52 MAIN BOARD (8/10) (Page 25)

44 MAIN BOARD (6/10) (Page 23)

14 MAIN BOARD (4/10) (Page 21)

48 MAIN BOARD (7/10) (Page 24)

51 MAIN BOARD (7/10) (Page 24)

40 MAIN BOARD (5/10) (Page 22)

6-16. PRINTED WIRING BOARD - CONNECT FLEXIBLE Board -

-  : Uses unleaded solder.

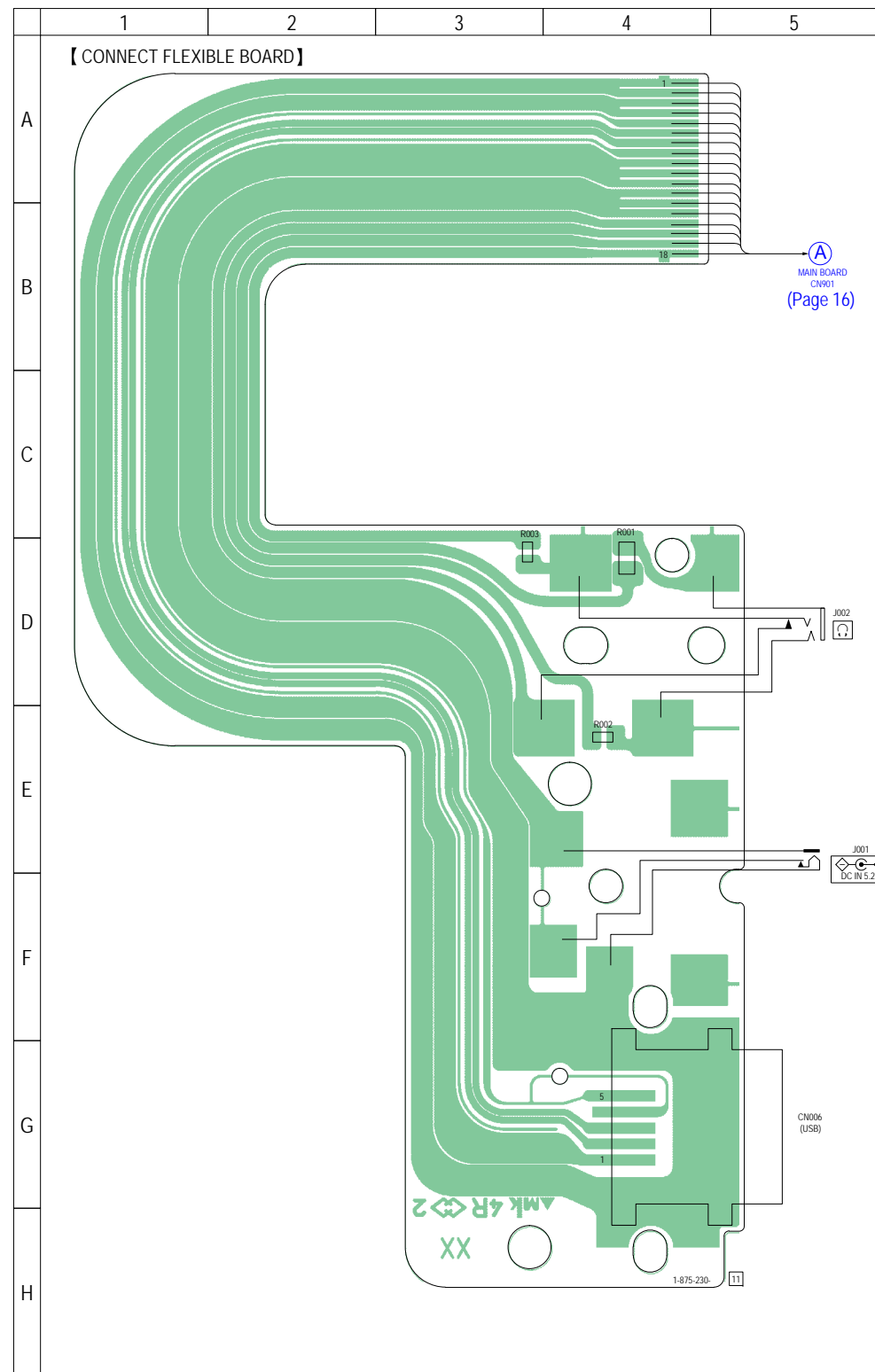

6-17. SCHEMATIC DIAGRAM - CONNECT FLEXIBLE Board -

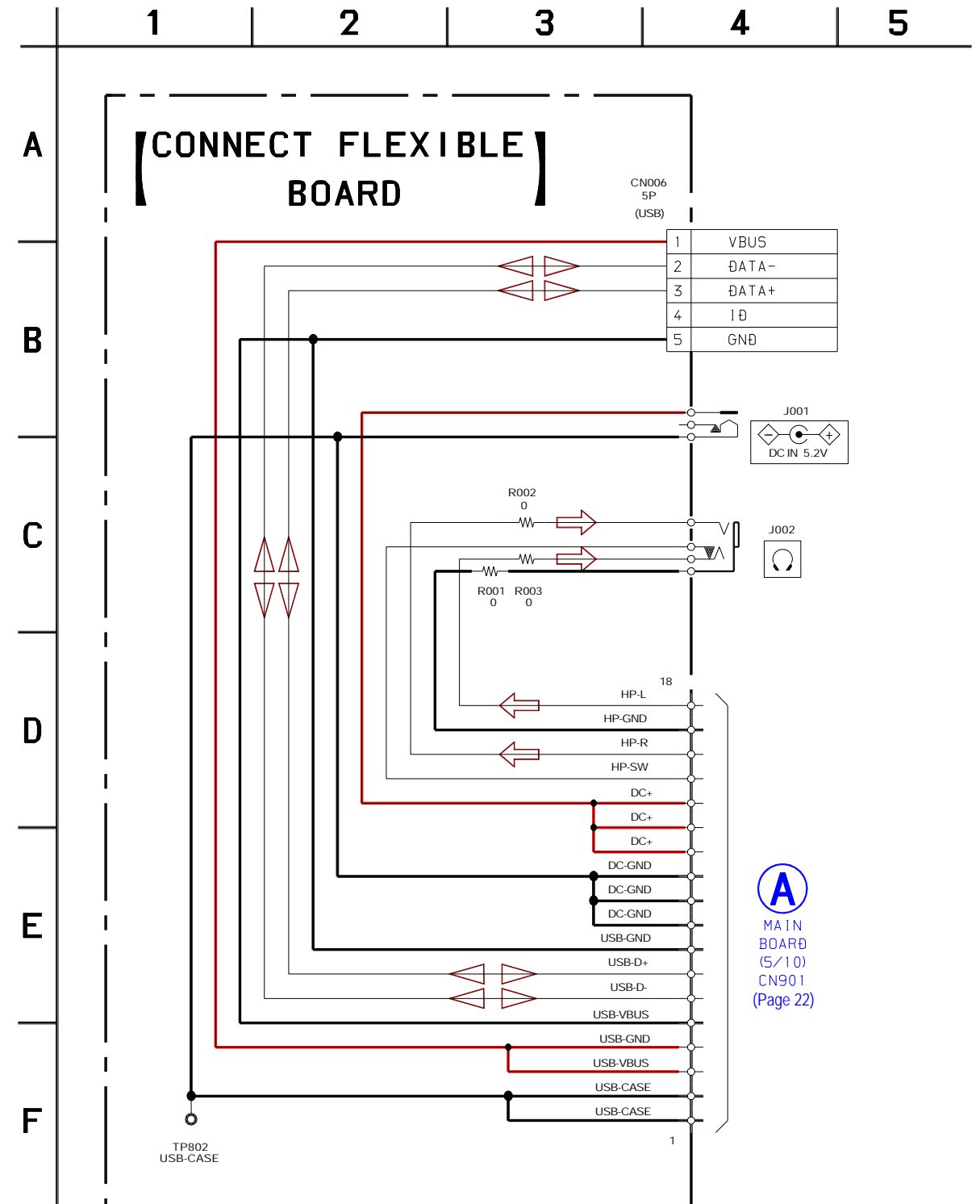

Note: When CONNECT FLEXIBLE board is defective, exchange the entire mounted board.

Note: When CONNECT FLEXIBLE board is defective, exchange the entire mounted board.

• IC Block Diagrams
– MAIN Board –

IC101 AK4365VN-L

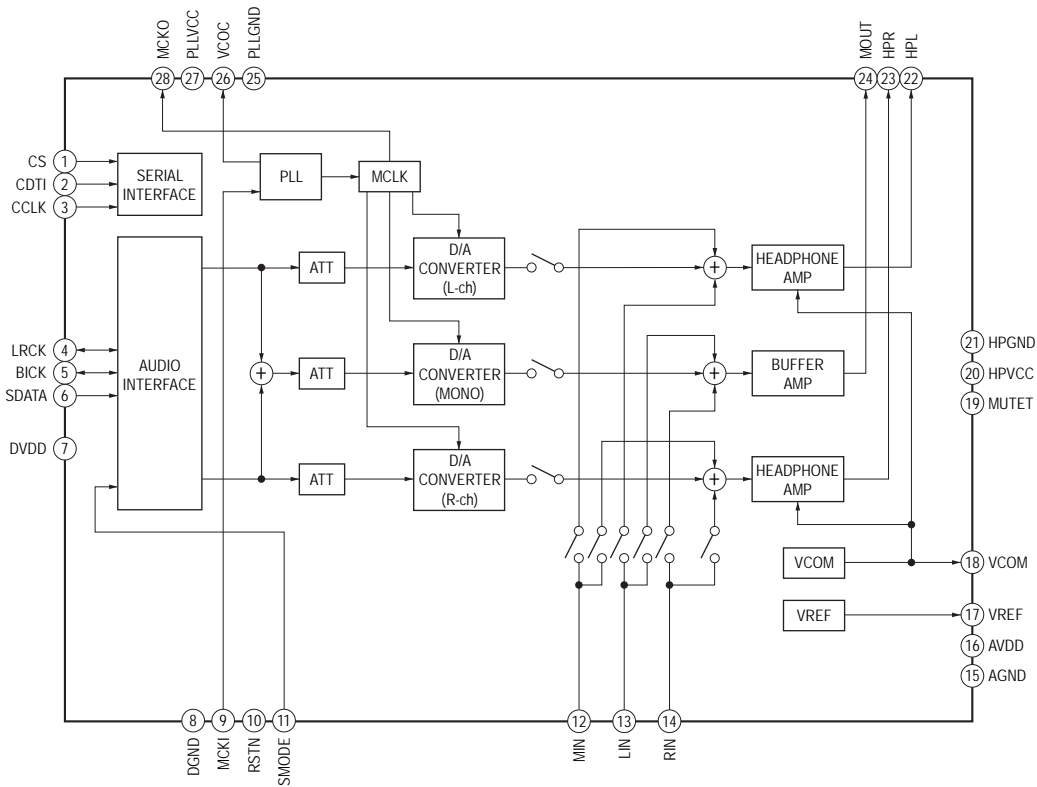

IC203 TC74LCX138FK (EL, K)

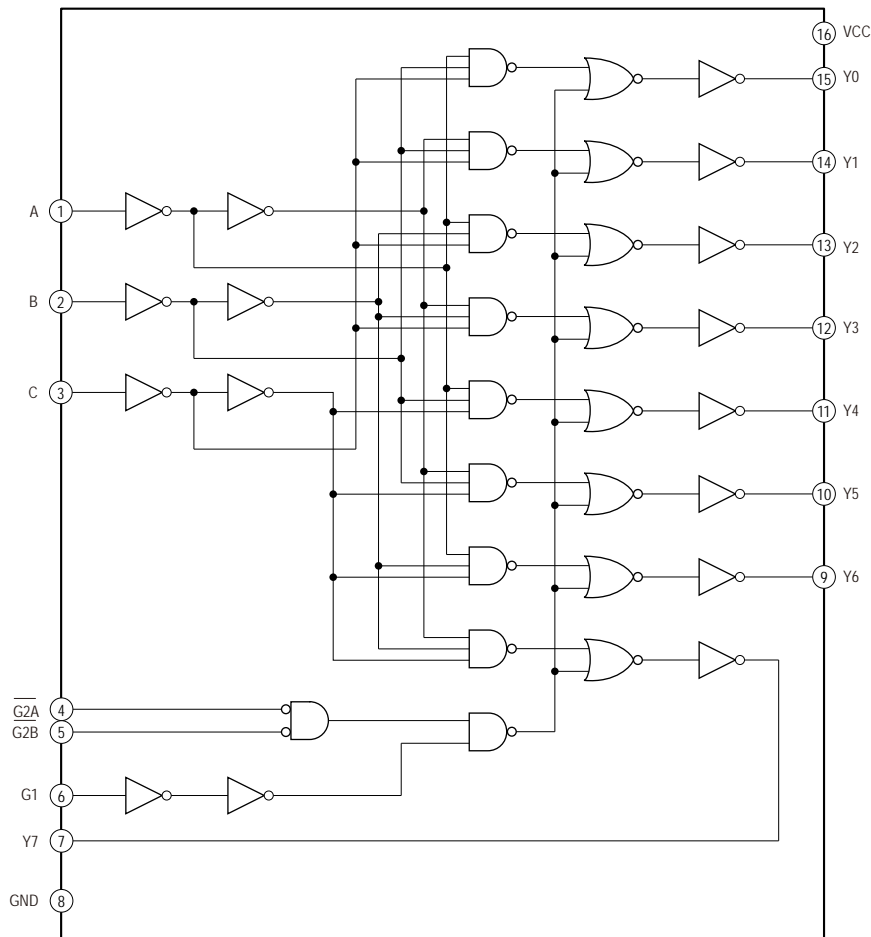

IC204, 205, 409 XC6213B312NR

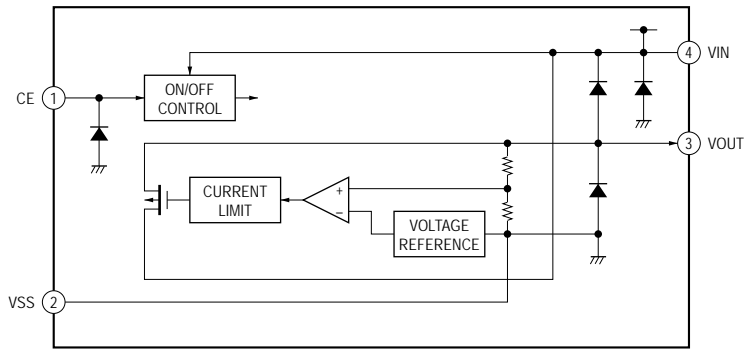

IC302 XC6215B152NR
 IC303 XC6215B312NR
 IC406 XC6215B292NR

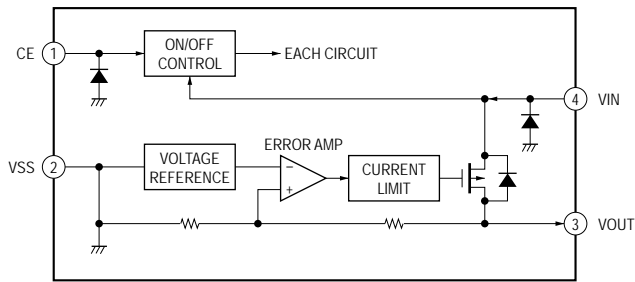

IC402 XC9226A296MR
 IC403 XC9226A196MR

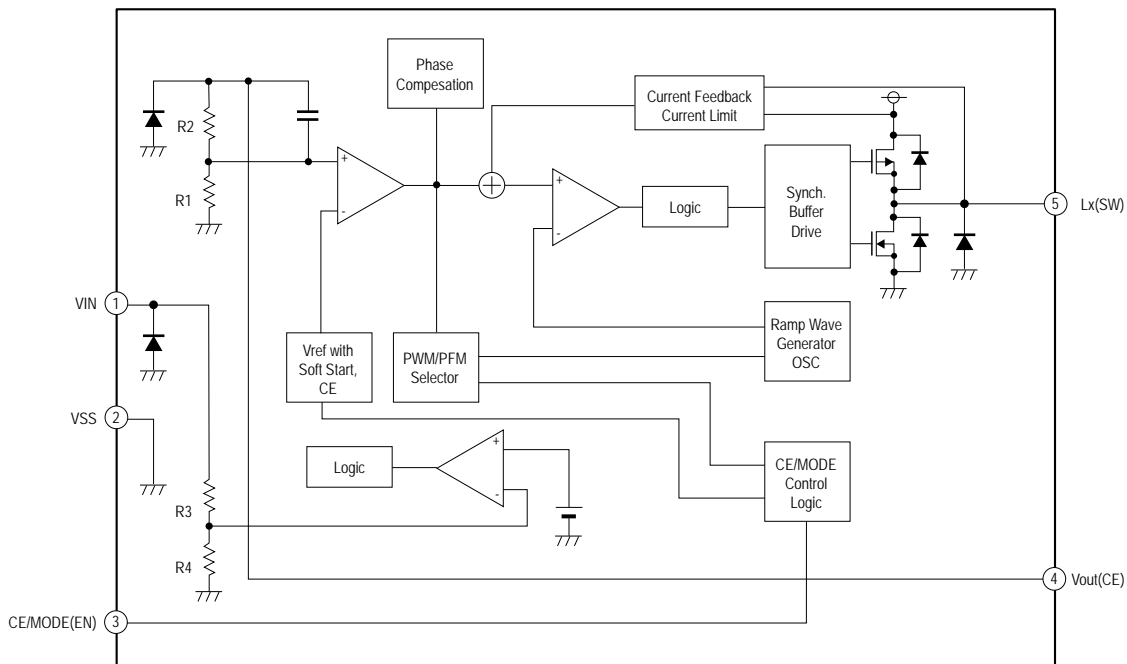

IC407 TC7WH74FK(TE85R)

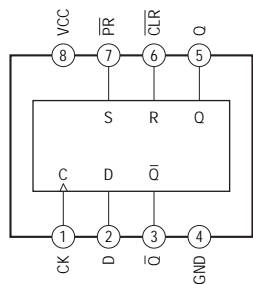

IC953 S1R72V17B00A20B

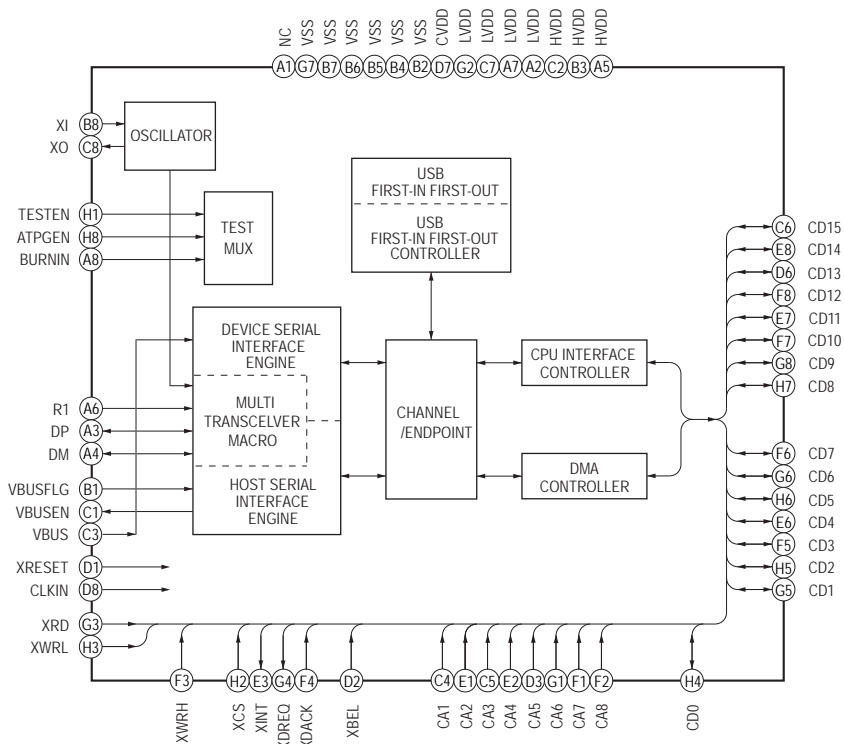

IC1002 TMP75AIDR

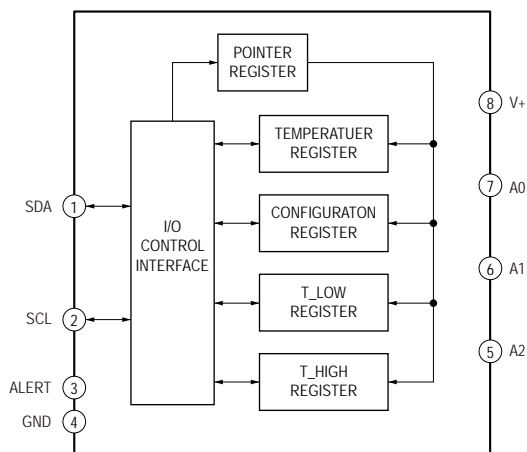

IC1101, 1102 TC7MP245FK (EL)

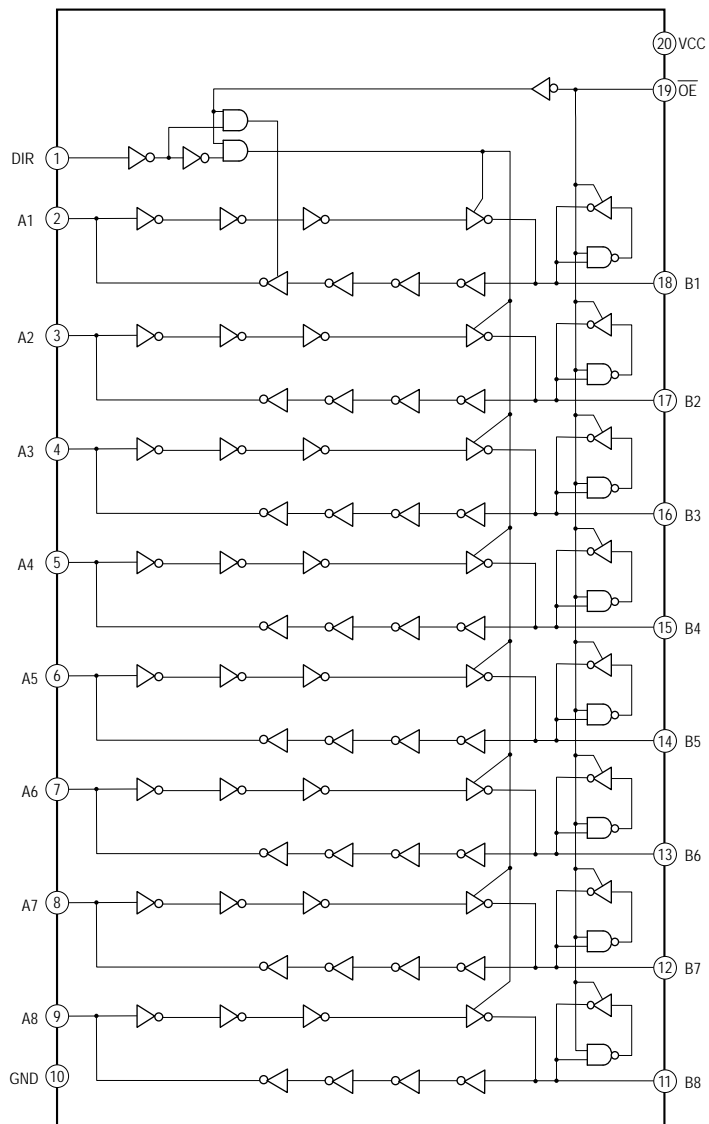

IC1112, 1113 SN74LVC244APWR

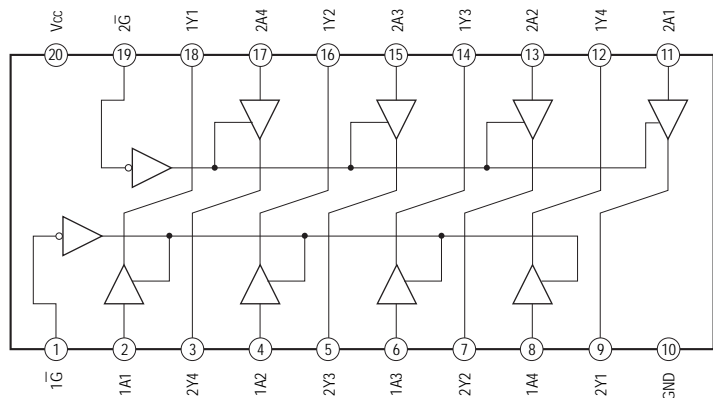

IC1802 LT3467ES6#TR

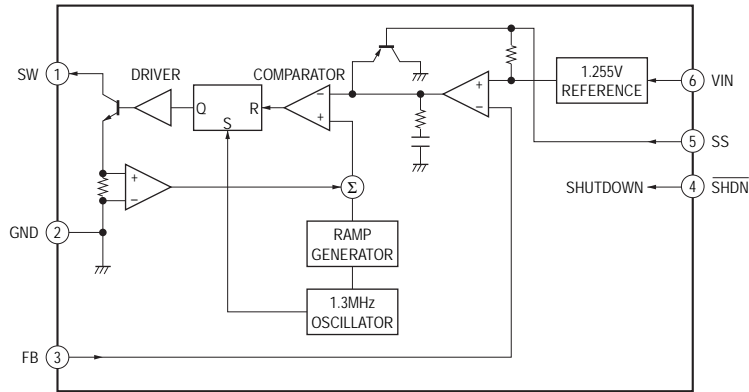

IC1805 LT1931ES5#TR

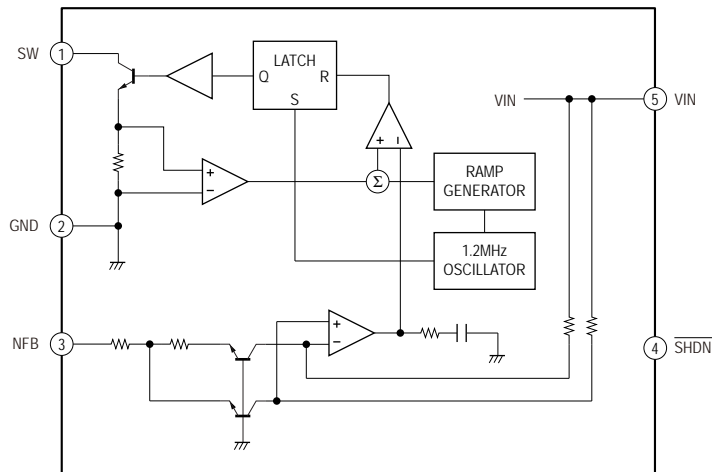

IC1806 TC7W53FK (TE85R)

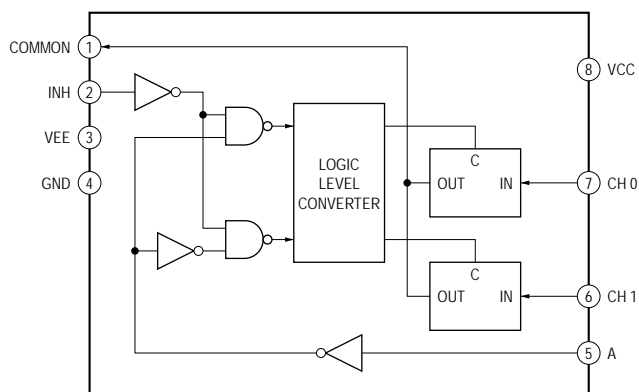

• IC Pin Function Description

MAIN BOARD IC201 R5C807 (MEMORY STICK DUO/SD MEMORY CARD CONTROLLER)

Pin No.	Pin Name	I/O	Description
1	VCCEN	O	+3.3V power supply control signal output terminal Not used
2	GPIO	I/O	Not used
3	LED	O	Not used
4	HWSPND	I	Hardware suspend mode select signal input from the main CPU "L": hardware suspend mode
5	RWMODE	I	Read-write timing mode select signal input terminal "H": maximum cycle time Fixed at "H" in this set
6	WAMODE	I	WAIT/DTACK mode select signal input terminal "L": DTACK mode, "H": WAIT mode Fixed at "L" in this set
7	LTLEN	I	Little/big endian select signal input terminal "L": little endian mode, "H": big endian mode Fixed at "L" in this set
8	TEST	I	Test mode terminal Normally fixed at "L"
9	CKIN	I	Host colck signal input from the main CPU
10	GND	-	Ground terminal
11	RST	I	Reset signal input terminal "L": reset
12	VCC_ROUT	-	Power supply terminal (+1.8V)
13	VCC_RIN	-	Power supply terminal (+1.8V)
14	REGEN	I	Internal regulator control signal input terminal "L": regulator on Fixed at "H" in this set
15	INT	O	Interrupt request signal output to the main CPU
16	WAIT/DTACK	O	Data acknowledge signal output terminal Not used
17	WR	I	Write enable signal input from the main CPU
18	RD	I	Read enable signal input from the main CPU
19, 20	EB0, EB1	I	Byte enable signal input terminal Not used
21	VCC_HOST	-	Power supply terminal (+3.3V)
22	CS	I	Chip select signal input from the address decoder
23 to 30	D15 to D8	I/O	Two-way data bus with the USB controller, main CPU, SD-RAM and NOR flash memory
31 to 33	D7 to D5	I/O	Two-way data bus with the USB controller, main CPU, NAND flash memory, SD-RAM and NOR flash memory
34	GND	-	Ground terminal
35 to 39	D0 to D4	I/O	Two-way data bus with the USB controller, main CPU, NAND flash memory, SD-RAM and NOR flash memory
40	BS	I	Bus cycle start signal input terminal Not used
41	A22	I	Address signal input terminal Not used
42	VCC_ROUT	-	Power supply terminal (+1.8V)
43 to 47	A21 to A17	I	Address signal input terminal Not used
48	VCC_HOST	-	Power supply terminal (+3.3V)
49	A16	I	Address signal input terminal Not used
50 to 64	A15 to A1	I	Address signal input from the main CPU
65	A0	I	Address signal input terminal Not used
66	GND	-	Ground terminal
67	SDCD	I	SD memory card detect signal input from the SD memory card slot "L": SD memory card slot in
68	SDDAT3	I/O	Two-way 4-bits data bus with the SD memory card slot
69	MDIO11	I/O	Not used
70	MSDAT0	I/O	Two-way data bus with the memory stick duo slot
71	MDIO12	I/O	Not used
72	MSDAT1	I/O	Two-way data bus with the memory stick duo slot
73	VCC_3V	-	Power supply terminal (+3.3V)
74	MDIO13	I/O	Not used
75	MSDAT2	I/O	Two-way data bus with the memory stick duo slot
76	MDIO14	I/O	Not used
77	MSDAT3	I/O	Two-way data bus with the memory stick duo slot
78 to 84	MDIO15, MDIO19 to MDIO24	I/O	Not used
85	SDWP	I	SD memory card write protect switch signal input from the SD memory card slot
86	VCC_ROUT	-	Power supply terminal (+1.8V)
87	MSCLK	O	Serial clock signal output to the memory stick duo slot
88	MDIO17	I/O	Not used
89	SDCLK	O	Serial clock signal output to the SD memory card slot

Pin No.	Pin Name	I/O	Description
90	GND	-	Ground terminal
91, 92	SDDAT0, SDDAT1	I/O	Two-way 4-bits data bus with the SD memory card slot
93	MSBS	O	Bus state signal output to the memory stick duo slot
94	SDDAT2	I/O	Two-way 4-bits data bus with the SD memory card slot
95	MDIO09	I/O	Not used
96	VCC_3V	-	Power supply terminal (+3.3V)
97	SDCMD	I/O	Command signal input/output with the SD memory card slot
98	MDIO27	I/O	Not used
99	MSCD	I	Memory stick duo detect signal input from the memory stick duo slot "L": memory stick duo slot in
100	MDIO29	I/O	Not used

MAIN BOARD IC301 A3P125-VQG100 (INDICATOR CONTROLLER)

Pin No.	Pin Name	I/O	Description
1	GND	-	Ground terminal
2 to 8	PD15 to PD9	I	Video data input from the main CPU
9	GND	-	Ground terminal
10, 11	PD8, PD7	I	Video data input from the main CPU
12	GND	-	Ground terminal
13	PD6	I	Video data input from the main CPU
14	GND	-	Ground terminal
15, 16	PD5, PD4	I	Video data input from the main CPU
17	VCC	-	Power supply terminal (+1.5V)
18	VCCI	-	Power supply terminal (+3.3V)
19 to 22	PD3 to PD0	I	Video data input from the main CPU
23	PSFL	I	Not used
24	VMV	-	Power supply terminal (+3.3V)
25	GND	-	Ground terminal
26	FCLK	I	Frame clock signal input from the main CPU
27	LCLK	I	Latch clock signal input from main CPU
28	PCLK	I	Pixel clock signal input from the main CPU
29	SDLE	O	Latch enable signal output to the ink indicator element
30 to 36	SDDO0 to SDDO6	O	Video data input from the main CPU
37	VCC	-	Power supply terminal (+1.5V)
38	GND	-	Ground terminal
39	VCC1	-	Power supply terminal (+3.3V)
40	SDDO7	O	Video data input from the main CPU
41	SDCLK	O	Clock signal output to the ink indicator element
42	SDOE	O	Output enable signal output to the ink indicator element
43	GDOE	O	Output enable signal output to the ink indicator element
44	GDSP	O	Sharp panel signal output to the ink indicator element
45	GDCLK	O	Clock signal output to the ink indicator element
46	GND	-	Ground terminal
47	TCK	-	Not used
48	TDI	-	Not used
49	TMS	-	Not used
50	VMV	-	Power supply terminal (+3.3V)
51	GND	-	Ground terminal
52	VPUMP	-	Not used
53	NC	-	Not used
54	TDO	-	Not used
55	TRST	-	Not used
56	VJTAG	-	Not used
57 to 59	SDCE5 to SDCE3	O	Chip enable signal output terminal Not used
60 to 62	SDCE2 to SDCE0	O	Chip enable signal output to the ink indicator element
63	SDSHR	O	Not used
64	GDRL	O	Not used
65	PWRCOM	O	Command signal output to the VCOM switch
66	VCCI	-	Power supply terminal (+3.3V)
67	GND	-	Ground terminal
68	VCC	-	Power supply terminal (+1.5V)
69	PWR2	O	Power supply control signal output terminal
70	BDR1	O	Border control signal output terminal
71	BDR0	O	Border control signal output terminal
72	PWR0	O	Power supply control signal output terminal
73	PWR1	O	Power supply control signal output terminal
74	VMV	-	Power supply terminal (+3.3V)
75	GND	-	Ground terminal
76	SPIDO	O	Not used
77	SPICLK	O	Not used
78	SPIDI	I	Not used
79	SPICS	O	Not used

Pin No.	Pin Name	I/O	Description
80	I2CSCL	O	Not used
81	I2CSDA	I/O	Not used
82	PWR3	O	Not used
83	RESERVED	-	Not used
84 to 86	TEST2 to TEST0	I	Ground terminal
87	VCCIB	-	Power supply terminal (+3.3V)
88	GND	-	Ground terminal
89	VCC	-	Power supply terminal (+1.5V)
90 to 92	RESERVED	-	Not used
93	PDOE	I	Output enable signal input from the main CPU
94	RESET	I	Reset signal input from the main CPU
95	RDY	O	Ready signal output to the main CPU
96	STBY	I	Standby signal input from the main CPU
97	ERR	O	Error signal output to the main CPU
98	RESERVED	-	Not used
99	GND	-	Ground terminal
100	VMV	-	Power supply terminal (+3.3V)

MAIN BOARD IC401 SN412005RHLR (CHARGE CONTROL)

Pin No.	Pin Name	I/O	Description
1	LDO	O	Power supply (+3.3V) output terminal
2	STAT1	O	Charge state signal output to the sub CPU and LED drive signal for CHARGE indicator
3	STAT2	O	Charge state signal output to the sub CPU
4	AC	I	Power supply input from the AC adaptor
5, 6	BAT	I/O	Power supply voltage input from the rechargeable battery or charge voltage output to the rechargeable battery
7	ISET2	I	Charge current setting signal input from the sub CPU "L": 100 mA, "H": 500 mA Fixed at "H" charging voltage in this set
8	PSEL	I	Charge source selection signal input terminal "L": USB (pin 20), "H": AC (pin 4) Fixed at "H" charging voltage in this set
9	CE	I	Chip enable signal input terminal Not used
10	ISET1	O	Setting terminal for AC input charge current and AC precharge/termination
11	VSS	-	Ground terminal
12	TS	I	Thermal detection signal input terminal
13	DPPM	I	Setting terminal for the dynamic power pass management
14	TMR	I	Timer program input terminal (Becomes impossible to do safety timer and charge termination when connecting LOD (pin 1))
15 to 17	OUT	O	Power supply voltage output terminal
18	XACPG	O	External DC power state detection signal output to the sub CPU "L": external DC power on
19	XUSBPG	O	USB power state detection signal output terminal Not used
20	USB	I	Charge voltage input terminal from the USB connector
21	GND	-	Ground terminal

MAIN BOARD IC801 HD64F38004FP10V-V198 (SUB CPU)

Pin No.	Pin Name	I/O	Description
1	BATT-DC	I	Power supply input from the AC adaptor
2	X1	I	System clock input terminal (32.768 kHz)
3	X2	O	System clock output terminal (32.768 kHz)
4	VSS	-	Ground terminal
5	OSC2	O	System clock output terminal (4.9152 MHz)
6	OSC1	I	System clock input terminal (4.9152 MHz)
7	TEST	I	Connect to ground
8	XRESET	I	System reset signal input terminal "L": reset
9	ISET1	I	Charge current setting signal input terminal
10	ISET2	O	Charge current setting signal output to the charge control
11 to 13	P33 to P35	-	Connect to power supply
14, 15	STAT1, STAT2	I	Charge state monitor input from the charge control
16	VCC	-	Power supply terminal (+2.9V)
17 to 19	V1 to V3	-	Connect to power supply
20	PWRON	O	Main power on/off control signal output terminal "H": main power on
21	AD_ON	O	Rechargeable battery input control signal output terminal "H": rechargeable battery input
22	POR	O	Power on reset signal output to the main CPU "H": reset
23	XM_RESET	O	Master reset signal output to the main CPU "L": reset
24	USBON	O	USB charge on/off control signal output terminal "H": USB charge on
25 to 29	KEY_OUT7 to KEY_OUT3	O	Key scan signal output terminal Not used
30 to 32	KEY_OUT2 to KEY_OUT0	O	Key scan signal output terminal
33 to 40	KEY_IN7 to KEY_IN0	I	Key scan signal input terminal
41	KEY-INT	I	Key scan interrupt input from the KEY-ON (pin 53)
42	CTS	I	Clear to send signal input from the main CPU
43	USBDET	I	USB cable connect signal input terminal "H": USB cable is connected
44	LOW-BATT-LI	I	Rechargeable battery low detect signal input terminal
45	WKP3	I	Not used
46	USBCHG	I	USB charge enable signal input from the main CPU
47	DCDET	I	External DC power state detection signal input from the charge control "L": external DC power on
48	STBY_SW	I	Power switch signal input terminal
49	KEYLED	O	LED drive signal output terminal Not used
50	LED_1	O	LED drive signal output terminal for USB indicator "H": LED on
51	LED_2	O	LED drive signal output terminal Not used
52	USBBOOT	O	Main CPU boot mode control signal output to the main CPU
53	KEY-ON	O	Key scan interrupt signal output to the KEY-INT (pin 41)
54	P95	O	Connect to power supply
55	VSS	-	Ground terminal
56	IRQAEC	I	Not used
57	RTS	O	Request to send signal output to the main CPU
58	RXD	I	Serial data input from the main CPU
59	TXD	O	Serial data output to the main CPU
60	IRQ0	I	Not used
61	AVCC	-	Power supply terminal (+2.9V)
62	AN0	I	Not used
63	BATT-LI	I	Rechargeable battery input terminal
64	AN2	I	Not used

MAIN BOARD IC1001 MC9328MXLVP20R2 (MAIN CPU)

Pin No.	Pin Name	I/O	Description
A1	AUDIO3_DATA	O	Serial data output to the audio D/A converter
A2	SRAMINT	I	Not used
A3	VBUS	I	VBUS input from the USB connector
A4	XUSB_D_OE	O	USB output enable signal output terminal Not used
A5	USB_D_SUSPND	O	USB suspend signal output terminal Not used
A6	USB_VM	I	USB minus input terminal Not used
A7	USB20INT	I	Interrupt signal input from the USB controller
A8	SSI_TXCLK	O	Bit clock signal output to the audio D/A converter
A9	NAND-CE1	O	Chip enable signal output terminal Not used
A10	NAND-CE0	O	Chip enable signal output to the NAND flash memory
A11	ERR	O	Error signal output to the indicator controller
A12	RDY	I	Ready signal input from the indicator controller
A13 to A15	PD2, PD4, PD5	O	Video data output to the indicator controller
B1	AUDIO1_CS	O	Chip select signal output to the audio D/A converter
B2	AUDIO2_CLK	O	Clock signal output to the audio D/A converter
B3	SD_DET	I	SD memory card detect signal input from the SD memory card slot "L": SD memory card slot in
B4	USB_D_AFE	O	USB analog front end enable signal output terminal Not used
B5	USB_D_RCV	I	USB serial data input terminal Not used
B6	USB_D_VMO	O	USB minus output terminal Not used
B7	SSI_RXDAT	I	Serial data input terminal Not used
B8	UART1_TXD	O	Serial data output to the sub CPU
B9	RY/#BY	I	Ready/busy select signal input from the NAND flash memory and NOR flash memory
B10	PCLK	O	Pixel clock signal output to the indicator controller
B11	STBY	O	Standby signal output to the indicator controller
B12 to B15	PD0, PD3, PD6, PD7	O	Video data output to the indicator controller
C1	D31	I/O	Two-way data bus with the SD-RAM
C2	USB_LED	O	LED drive signal output terminal for USB indicator "H": LED on
C3	MSINT	I	Not used
C4	SD_WP	I	SD memory card write protect switch signal input from the SD memory card slot
C5	PCAUDIO	O	Power supply on/off signal output terminal "H": power on
C6	USB_D_VPO	O	USB plus output terminal Not used
C7	UART2_RXD	I	Serial data input terminal Not used
C8	SSI_TXFS	O	L/R sampling clock signal output to the audio D/A converter
C9	UART1_RTS	I	Request to send signal input from the sub CPU
C10	SRA3P	O	Reset signal output to the indicator controller
C11	FCLK	O	Frame clock signal output to the indicator controller
C12 to C14	PD8, PD9, PD12	O	Video data output to the indicator controller
C15	NVDD2	-	Power supply terminal (+2.9V)
D1	A23	O	Address signal output to the address decoder
D2	A24	O	Address signal output terminal Not used
D3	PCR5CCLK	O	Host clock control signal output terminal
D4	PB17	O	Not used
D5	NVDD1	-	Power supply terminal (+2.9V)
D6	USB_D_VP	I	USB plus input terminal Not used
D7	QVDD4	-	Power supply terminal (+1.9V)
D8	UART2_TXD	O	Serial data output terminal Not used
D9	NVDD3	-	Power supply terminal (+2.9V)
D10	NAND-ALE	O	Address latch enable signal output to the NAND flash memory
D11	LCLK	O	Latch clock signal output to the indicator controller
D12, D13	PD1, PD11	O	Video data output to the indicator controller
D14	HPSET	I	Not used
D15	PD13	O	Video data output to the indicator controller
E1, E2	A21, A22	O	Address signal output to the address decoder
E3, E4	D30, D29	I/O	Two-way data bus with the SD-RAM
E5	NVDD1	-	Power supply terminal (+2.9V)
E6	VSS	-	Ground terminal
E7	PCSDCARD	O	Regulator control signal output terminal

Pin No.	Pin Name	I/O	Description
E8	UART1_RXD	I	Serial data input from the sub CPU
E9	UART1_CTS	O	Clear to send signal output to the sub CPU
E10	NAND-CLE	O	Command latch enable signal output to the NAND flash mamory
E11	PDOE	O	Output enable signal output to the indicator controller
E12	PD10	O	Video data output to the indicator controller
E13	TIN	I	Timer input terminal Not used
E14	PCA3PCORE	O	Regulator control signal output terminal
E15	SRETHET	O	Not used
F1, F2	A20, A19	O	Address signal output to the NOR flash memory
F3, F4	D28, D27	I/O	Two-way data bus with the SD-RAM
F5, F6	NVDD1	-	Power supply terminal (+2.9V)
F7	PCMSCARD	O	Regulator control signal output terminal
F8	SRUSB20	O	No used
F9	SSI_TXDAT	O	Audio data output to the audio D/A converter
F10	SRSRAM1	O	Not used
F11	QVDD3	-	Power supply terminal (+1.9V)
F12, F13	PD14, PD15	O	Video data output to the indicator controller
F14	USB_CHRG	O	USB charge enable signal output to the sub CPU
F15	SRDSP	O	Reset signal output to the audio D/A converter
G1, G2	A17, A18	O	Address signal output to the NOR flash memory
G3, G4	D26, D25	I/O	Two-way data bus with the SD-RAM
G5	NVDD1	-	Power supply terminal (+2.9V)
G6	VSS	-	Ground terminal
G7	NVDD4	-	Power supply terminal (+2.9V)
G8 to G10	VSS	-	Ground terminal
G11	PCA3PIO	O	Regulator control signal output terminal
G12	PCUSB11	O	Not used
G13	RSCINT	I	Interrupt request signal input from the memory stick duo/SD memory card controller
G14	MSDET	I	Memory stick duo detect signal input from the memory stick duo slot "L": memory stick duo slot in
G15	SRMS	O	Not used
H1	A15	O	Address signal output to the memory stick duo/SD memory card controller, SD-RAM and NOR flash memory
H2	A16	O	Address signal output to the NOR flash memory
H3 to H5	D22 to D24	I/O	Two-way data bus with the SD-RAM
H6 to H9	VSS	-	Ground terminal
H10	NVDD2	-	Power supply terminal (+2.9V)
H11	USB_BOOT	I	Main CPU boot mode control signal input from the sub CPU
H12	PCR5C	O	Hardware suspend mode output to the memory stick duo/SD memory card controller "L": hardware suspend mode
H13	PA14	O	Not used
H14	I2CSDA	I/O	Two-way IIC bus with the temperature sensor
H15	TMS	I	Test mode select signal input terminal Not used
J1, J2	A14, A12	O	Address signal output to the memory stick duo/SD memory card controller, SD-RAM and NOR flash memory
J3, J4	D21, D20	I/O	Two-way data bus with the SD-RAM
J5	NVDD1	-	Power supply terminal (+2.9V)
J6, J7	VSS	-	Ground terminal
J8	QVDD1	-	Power supply terminal (+1.9V)
J9	VSS	-	Ground terminal
J10	SRR5C	O	Reset signal output to the memory stick duo/SD memory card controller
J11	I2CSCL	O	IIC bus serial clock signal output to the temperature sensor
J12	TCK	I	Test clock signal input terminal Not used
J13	XTDO	O	Test data signal output terminal Not used
J14, J15	BOOT1, BOOT0	I	System boot mode select signal input terminal
K1	A13	O	Address signal output to the memory stick duo/SD memory card controller, SD-RAM and NOR flash memory
K2	A11	O	Address signal output to the memory stick duo/SD memory card controller and NOR flash memory
K3	XCS2	O	Chip select signal output to the SD-RAM
K4	D19	I/O	Two-way data bus with the SD-RAM

Pin No.	Pin Name	I/O	Description
K5	NVDD1	-	Power supply terminal (+2.9V)
K6, K7	VSS	-	Ground terminal
K8	NVDD1	-	Power supply terminal (+2.9V)
K9	VSS	-	Ground terminal
K10	D1	I/O	Two-way data bus with the memory stick duo/SD memory card controller, USB controller, NAND flash memory, SD-RAM and NOR flash memory
K11	BOOT2	I	System boot mode select signal input terminal
K12	TDI	I	Test data input terminal Not used
K13	BIG_ENDIAN	I	Not used
K14	XRESET-OUT	O	Reset signal output to the audio D/A converter, memory stick duo/SD memory card controller, USB controller, NAND flash memory and NOR flash memory
K15	XTAL32K	O	System clock output terminal (32.768 kHz)
L1, L2	A10, A9	O	Address signal output to the memory stick duo/SD memory card controller, SD-RAM and NOR flash memory
L3, L4	D17, D18	I/O	Two-way data bus with the SD-RAM
L5, L6	NVDD1	-	Power supply terminal (+2.9V)
L7	XCS5	O	Chip select signal output terminal
L8	D2	I/O	Two-way data bus with the memory stick duo/SD memory card controller, USB controller, NAND flash memory, SD-RAM and NOR flash memory
L9	PA20	O	Not used
L10, L11	VSS	-	Ground terminal
L12	POR	I	Power on reset signal input from the sub CPU "H": reset
L13	VSS	-	Ground terminal
L14	XTAL16M	O	System clock output terminal Not used
L15	EXTAL32K	I	System clock input terminal (32.768 kHz)
M1	D16	I/O	Two-way data bus with the SD-RAM
M2 to M4	D15, D13, D10	I/O	Two-way data bus with the memory stick duo/SD memory card controller, USB controller, SD-RAM and NOR flash memory
M5	XEB3	O	Byte strobe signal output terminal Not used
M6	NVDD1	-	Power supply terminal (+2.9V)
M7, M8	XCS4, XCS1	O	Chip select signal output terminal
M9	PA18	-	Not used
M10	XRW	O	Read/write enable signal output terminal
M11	VSS	-	Ground terminal
M12	BOOT3	I	System boot mode select signal input terminal
M13	QVDD2	-	Power supply terminal (+1.9V)
M14	XRESET-IN	I	Master reset signal input from the sub CPU "L": reset
M15	EXTAL16M	I	System clock input terminal Not used
N1, N2	A8, A7	O	Address signal output to the memory stick duo/SD memory card controller, USB controller, SD-RAM and NOR flash memory
N3	D12	I/O	Two-way data bus with the memory stick duo/SD memory card controller, USB controller, SD-RAM and NOR flash memory
N4	XEB0	O	Byte strobe signal output terminal Not used
N5, N6	D9, D8	I/O	Two-way data bus with the memory stick duo/SD memory card controller, USB controller, SD-RAM and NOR flash memory
N7, N8	XCS3, XCS0	O	Chip select signal output terminal
N9	PA17	-	Not used
N10	D0	I/O	Two-way data bus with the memory stick duo/SD memory card controller, USB controller, NAND flash memory, SD-RAM and NOR flash memory
N11, N12	DQM2, DQM0	O	Data enable signal output to the SD-RAM
N13	SDCK0	O	Clock enable signal output to the SD-RAM
N14	TRISTATE	I	Not used
N15	XTRST	I	Test reset signal input terminal Not used
P1	D14	I/O	Two-way data bus with the memory stick duo/SD memory card controller, USB controller, SD-RAM and NOR flash memory
P2	A1	O	Address signal output to the memory stick duo/SD memory card controller, USB controller and NOR flash memory
P3 to P6	A2 to A5	O	Address signal output to the memory stick duo/SD memory card controller, USB controller, SD-RAM and NOR flash memory
P7, P8	D6, D5	I/O	Two-way data bus with the memory stick duo/SD memory card controller, USB controller, NAND flash memory, SD-RAM and NOR flash memory
P9, P10	MA10, MA11	O	Address signal output to the SD-RAM

Pin No.	Pin Name	I/O	Description
P11	DQM1	O	Data enable signal output to the SD-RAM
P12	XRAS	O	Row address select signal output to the SD-RAM
P13	SDCKE1	O	Clock enable signal output to the SD-RAM Not used
P14	CLKO	O	Host clock signal output to the memory stick duo/SD memory card controller
P15	XRESET-SF	O	Not used
R1	A6	O	Address signal output to the memory stick duo/SD memory card controller, USB controller, SD-RAM and NOR flash memory
R2	D11	I/O	Two-way data bus with the memory stick duo/SD memory card controller, USB controller, SD-RAM and NOR flash memory
R3	XEB1	O	Byte strobe signal output terminal Not used
R4	XEB2	O	Write enable signal output to the memory stick duo/SD memory card controller, USB controller and NOR flash memory
R5	XOE	O	Read enable signal output terminal
R6	D7	I/O	Two-way data bus with the memory stick duo/SD memory card controller, USB controller, NAND flash memory, SD-RAM and NOR flash memory
R7	A0	O	Address signal output terminal Not used
R8	SDCLK	O	Clock output to the SD-RAM
R9	D4	I/O	Two-way data bus with the memory stick duo/SD memory card controller, USB controller, NAND flash memory, SD-RAM and NOR flash memory
R10	GPSRAM1	O	Not used
R11	D3	I/O	Two-way data bus with the memory stick duo/SD memory card controller, USB controller, NAND flash memory, SD-RAM and NOR flash memory
R12	DQM3	O	Data enable signal output to the SD-RAM
R13	XCAS	O	Column address select signal output to the SD-RAM
R14	XSDWE	O	Write enable signal output to the SD-RAM
R15	AVDD1	-	Power supply terminal (+2.9V)

7-2. MAIN SECTION

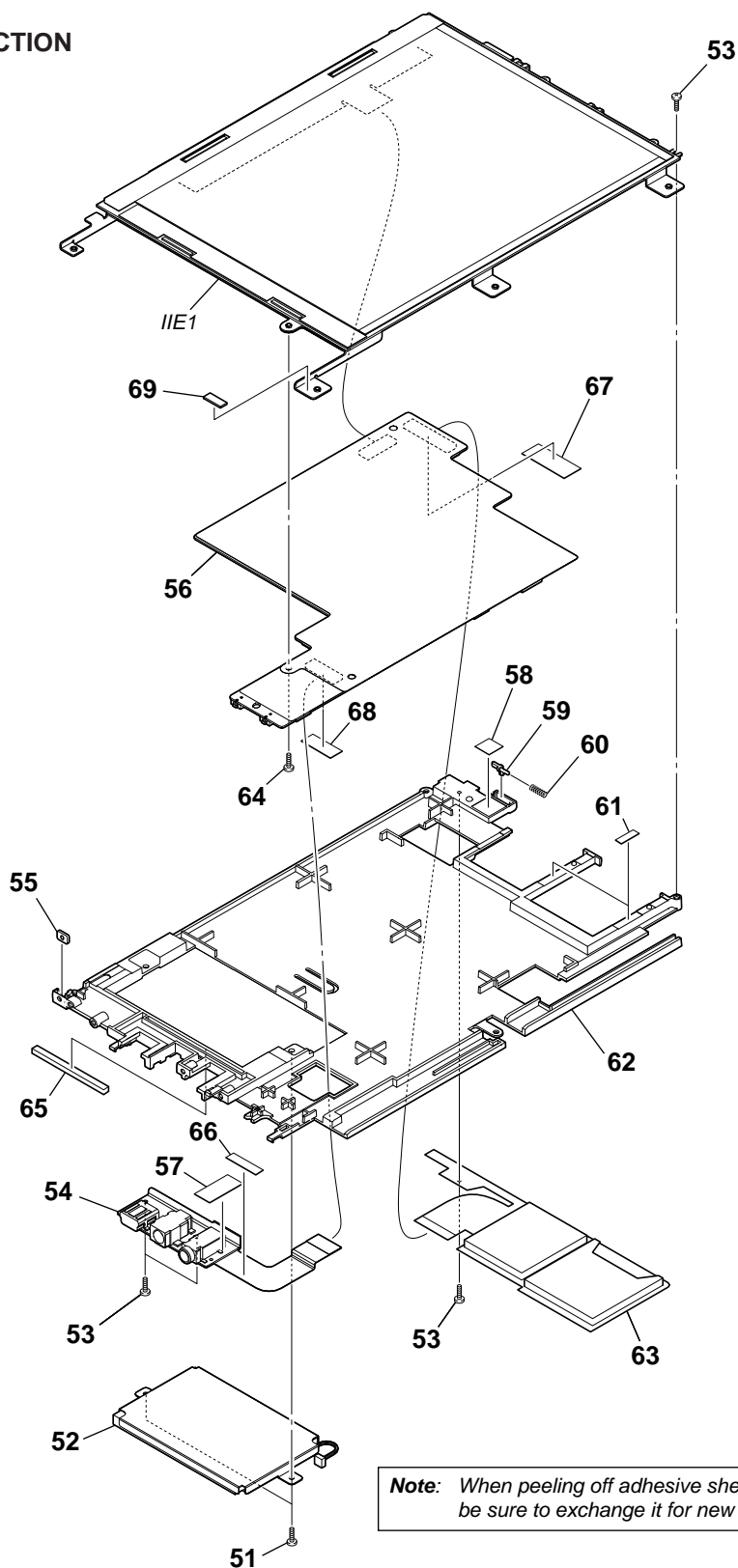

Ref. No.	Part No.	Description	Remark	Ref. No.	Part No.	Description	Remark
51	3-225-873-31	SCREW (M1.4)		61	3-274-373-01	SHEET (B), ADHESIVE	
52	X-2187-668-1	BATTERY ASSY. (ION) STORAGE		62	3-217-904-01	FRAME	
53	3-348-998-81	SCREW (M1.4)		63	A-1362-419-A	SLOT FLEXIBLE BOARD, COMPLETE	
54	A-1362-421-A	CONNECT FLEXIBLE BOARD, COMPLETE		64	3-335-797-01	SCREW (M1.4X2), TOOTHED LOCK	
55	3-269-318-01	NUT PLATE		65	3-281-571-01	SHEET (BATT), RUBBER	
56	X-2187-667-1	MAIN BOARD, COMPLETE (for SERVICE)		66	3-277-818-01	SHEET (D), ADHESIVE	
57	3-283-362-01	COPPER LEAF SHEET B		67	3-280-819-01	SPACER (CON_SD)	
58	3-269-553-01	SHEET (A), ADHESIVE		68	3-280-818-01	SPACER (CON_USB)	
59	3-217-911-01	SHAFT (SPRING)		69	3-275-559-01	SHEET (R2)	
60	3-260-808-01	SPRING, COMPRESSION		IIE1	X-2187-669-2	ELEMENT ASSY, INK (INDICATION)	

SECTION 8
ELECTRICAL PARTS LIST

Note:

- Due to standardization, replacements in the parts list may be different from the parts specified in the diagrams or the components used on the set.
- -XX and -X mean standardized parts, so they may have some difference from the original one.
- Items marked "*" are not stocked since they are seldom required for routine service. Some delay should be anticipated when ordering these items.
- CAPACITORS
uF: µF

- COILS
uH: µH
- RESISTORS
All resistors are in ohms.
METAL: Metal-film resistor.
METAL OXIDE: Metal oxide-film resistor.
F: nonflammable
- SEMICONDUCTORS
In each case, u: µ, for example:
uA. . . : µA. . . , uPA. . . , µPA. . . ,
uPB. . . : µPB. . . , uPC. . . , µPC. . . ,
uPD. . . : µPD. . .

When indicating parts by reference number, please include the board name.

The components identified by mark \triangle or dotted line with mark \triangle are critical for safety.
Replace only with part number specified.

Les composants identifiés par une marque \triangle sont critiques pour la sécurité.
Ne les remplacer que par une pièce portant le numéro spécifié.

Ref. No.	Part No.	Description	Remark
	A-1362-421-A	CONNECT FLEXIBLE BOARD, COMPLETE *****	
When CONNECT FLEXIBLE board is defective, exchange the entire mounted board. *****			
	X-2187-667-1	MAIN BOARD, COMPLETE (for SERVICE) ***** < CAPACITOR >	
C103	1-164-937-11	CERAMIC CHIP 0.001uF	10% 50V
C104	1-125-777-11	CERAMIC CHIP 0.1uF	10% 10V
C107	1-164-943-81	CERAMIC CHIP 0.01uF	10% 16V
C108	1-164-943-81	CERAMIC CHIP 0.01uF	10% 16V
C109	1-164-941-11	CERAMIC CHIP 0.0047uF	10% 16V
C110	1-125-777-11	CERAMIC CHIP 0.1uF	10% 10V
C111	1-165-989-11	CERAMIC CHIP 10uF	10% 6.3V
C112	1-125-777-11	CERAMIC CHIP 0.1uF	10% 10V
C113	1-125-777-11	CERAMIC CHIP 0.1uF	10% 10V
C114	1-125-777-11	CERAMIC CHIP 0.1uF	10% 10V
C115	1-165-989-11	CERAMIC CHIP 10uF	10% 6.3V
C116	1-165-908-11	CERAMIC CHIP 1uF	10% 10V
C117	1-165-989-11	CERAMIC CHIP 10uF	10% 6.3V
C118	1-165-989-11	CERAMIC CHIP 10uF	10% 6.3V
C119	1-165-989-11	CERAMIC CHIP 10uF	10% 6.3V
C120	1-125-777-11	CERAMIC CHIP 0.1uF	10% 10V
C121	1-125-777-11	CERAMIC CHIP 0.1uF	10% 10V
C122	1-125-777-11	CERAMIC CHIP 0.1uF	10% 10V
C123	1-165-989-11	CERAMIC CHIP 10uF	10% 6.3V
C124	1-125-777-11	CERAMIC CHIP 0.1uF	10% 10V
C128	1-137-859-11	TANTALUM CHIP 220uF	20% 4V
C129	1-137-859-11	TANTALUM CHIP 220uF	20% 4V
C141	1-164-943-81	CERAMIC CHIP 0.01uF	10% 16V
C201	1-125-777-11	CERAMIC CHIP 0.1uF	10% 10V
C202	1-165-989-11	CERAMIC CHIP 10uF	10% 6.3V
C203	1-125-777-11	CERAMIC CHIP 0.1uF	10% 10V
C204	1-125-777-11	CERAMIC CHIP 0.1uF	10% 10V
C205	1-125-777-11	CERAMIC CHIP 0.1uF	10% 10V
C206	1-125-777-11	CERAMIC CHIP 0.1uF	10% 10V
C207	1-125-777-11	CERAMIC CHIP 0.1uF	10% 10V
C208	1-125-777-11	CERAMIC CHIP 0.1uF	10% 10V
C209	1-165-989-11	CERAMIC CHIP 10uF	10% 6.3V
C210	1-125-777-11	CERAMIC CHIP 0.1uF	10% 10V
C211	1-125-777-11	CERAMIC CHIP 0.1uF	10% 10V
C212	1-125-777-11	CERAMIC CHIP 0.1uF	10% 10V

Ref. No.	Part No.	Description	Remark
C213	1-125-777-11	CERAMIC CHIP 0.1uF	10% 10V
C214	1-165-989-11	CERAMIC CHIP 10uF	10% 6.3V
C215	1-125-777-11	CERAMIC CHIP 0.1uF	10% 10V
C216	1-100-506-91	CERAMIC CHIP 1uF	20% 6.3V
C217	1-100-506-91	CERAMIC CHIP 1uF	20% 6.3V
C218	1-100-506-91	CERAMIC CHIP 1uF	20% 6.3V
C219	1-100-506-91	CERAMIC CHIP 1uF	20% 6.3V
C220	1-165-989-11	CERAMIC CHIP 10uF	10% 6.3V
C221	1-125-777-11	CERAMIC CHIP 0.1uF	10% 10V
C222	1-165-989-11	CERAMIC CHIP 10uF	10% 6.3V
C223	1-125-777-11	CERAMIC CHIP 0.1uF	10% 10V
C225	1-164-937-11	CERAMIC CHIP 0.001uF	10% 50V
C226	1-125-777-11	CERAMIC CHIP 0.1uF	10% 10V
C227	1-164-943-81	CERAMIC CHIP 0.01uF	10% 16V
C228	1-125-777-11	CERAMIC CHIP 0.1uF	10% 10V
C301	1-100-506-91	CERAMIC CHIP 1uF	20% 6.3V
C302	1-100-506-91	CERAMIC CHIP 1uF	20% 6.3V
C303	1-100-506-91	CERAMIC CHIP 1uF	20% 6.3V
C304	1-100-506-91	CERAMIC CHIP 1uF	20% 6.3V
C305	1-125-777-11	CERAMIC CHIP 0.1uF	10% 10V
C306	1-125-777-11	CERAMIC CHIP 0.1uF	10% 10V
C308	1-125-777-11	CERAMIC CHIP 0.1uF	10% 10V
C309	1-100-506-91	CERAMIC CHIP 1uF	20% 6.3V
C310	1-115-339-11	CERAMIC CHIP 0.1uF	10% 50V
C311	1-119-869-91	CERAMIC CHIP 10uF	35V
C312	1-113-987-11	TANTALUM CHIP 4.7uF	20% 25V
C313	1-113-987-11	TANTALUM CHIP 4.7uF	20% 25V
C314	1-125-777-11	CERAMIC CHIP 0.1uF	10% 10V
C315	1-125-777-11	CERAMIC CHIP 0.1uF	10% 10V
C316	1-125-777-11	CERAMIC CHIP 0.1uF	10% 10V
C317	1-125-777-11	CERAMIC CHIP 0.1uF	10% 10V
C318	1-125-777-11	CERAMIC CHIP 0.1uF	10% 10V
C319	1-125-777-11	CERAMIC CHIP 0.1uF	10% 10V
C320	1-125-777-11	CERAMIC CHIP 0.1uF	10% 10V
C321	1-125-777-11	CERAMIC CHIP 0.1uF	10% 10V
C322	1-125-777-11	CERAMIC CHIP 0.1uF	10% 10V
C323	1-125-777-11	CERAMIC CHIP 0.1uF	10% 10V
C324	1-125-777-11	CERAMIC CHIP 0.1uF	10% 10V
C325	1-125-777-11	CERAMIC CHIP 0.1uF	10% 10V
C326	1-165-989-11	CERAMIC CHIP 10uF	10% 6.3V
C401	1-100-672-11	CERAMIC CHIP 10uF	20% 16V
C402	1-100-672-11	CERAMIC CHIP 10uF	20% 16V
C403	1-100-672-11	CERAMIC CHIP 10uF	20% 16V
C404	1-125-777-11	CERAMIC CHIP 0.1uF	10% 10V
C405	1-164-938-11	CERAMIC CHIP 0.0015uF	10% 50V

Ref. No.	Part No.	Description			Remark	Ref. No.	Part No.	Description			Remark
C406	1-100-672-11	CERAMIC CHIP	10uF	20%	16V	C1012	1-125-777-11	CERAMIC CHIP	0.1uF	10%	10V
C407	1-127-760-11	CERAMIC CHIP	4.7uF	10%	6.3V	C1013	1-125-777-11	CERAMIC CHIP	0.1uF	10%	10V
C408	1-100-672-11	CERAMIC CHIP	10uF	20%	16V	C1014	1-125-777-11	CERAMIC CHIP	0.1uF	10%	10V
C411	1-165-989-11	CERAMIC CHIP	10uF	10%	6.3V	C1015	1-125-777-11	CERAMIC CHIP	0.1uF	10%	10V
C412	1-165-989-11	CERAMIC CHIP	10uF	10%	6.3V	C1016	1-125-777-11	CERAMIC CHIP	0.1uF	10%	10V
C413	1-127-760-11	CERAMIC CHIP	4.7uF	10%	6.3V	C1017	1-125-777-11	CERAMIC CHIP	0.1uF	10%	10V
C416	1-165-989-11	CERAMIC CHIP	10uF	10%	6.3V	C1018	1-165-989-11	CERAMIC CHIP	10uF	10%	6.3V
C417	1-165-989-11	CERAMIC CHIP	10uF	10%	6.3V	C1019	1-125-777-11	CERAMIC CHIP	0.1uF	10%	10V
C418	1-125-777-11	CERAMIC CHIP	0.1uF	10%	10V	C1020	1-125-777-11	CERAMIC CHIP	0.1uF	10%	10V
C419	1-100-506-91	CERAMIC CHIP	1uF	20%	6.3V	C1021	1-164-846-11	CERAMIC CHIP	6PF	0.5PF	50V
C420	1-100-506-91	CERAMIC CHIP	1uF	20%	6.3V	C1022	1-164-846-11	CERAMIC CHIP	6PF	0.5PF	50V
C421	1-125-777-11	CERAMIC CHIP	0.1uF	10%	10V	C1023	1-125-777-11	CERAMIC CHIP	0.1uF	10%	10V
C422	1-125-777-11	CERAMIC CHIP	0.1uF	10%	10V	C1024	1-125-777-11	CERAMIC CHIP	0.1uF	10%	10V
C423	1-125-777-11	CERAMIC CHIP	0.1uF	10%	10V	C1025	1-125-777-11	CERAMIC CHIP	0.1uF	10%	10V
C424	1-125-777-11	CERAMIC CHIP	0.1uF	10%	10V	C1028	1-125-777-11	CERAMIC CHIP	0.1uF	10%	10V
C425	1-164-156-11	CERAMIC CHIP	0.1uF		25V	C1029	1-125-777-11	CERAMIC CHIP	0.1uF	10%	10V
C426	1-164-156-11	CERAMIC CHIP	0.1uF		25V	C1030	1-125-777-11	CERAMIC CHIP	0.1uF	10%	10V
C427	1-125-777-11	CERAMIC CHIP	0.1uF	10%	10V	C1031	1-125-777-11	CERAMIC CHIP	0.1uF	10%	10V
C429	1-100-506-91	CERAMIC CHIP	1uF	20%	6.3V	C1032	1-164-943-81	CERAMIC CHIP	0.01uF	10%	16V
C430	1-100-506-91	CERAMIC CHIP	1uF	20%	6.3V	C1033	1-125-777-11	CERAMIC CHIP	0.1uF	10%	10V
C449	1-125-777-11	CERAMIC CHIP	0.1uF	10%	10V	C1034	1-125-777-11	CERAMIC CHIP	0.1uF	10%	10V
C801	1-165-989-11	CERAMIC CHIP	10uF	10%	6.3V	C1035	1-164-943-81	CERAMIC CHIP	0.01uF	10%	16V
C802	1-164-943-81	CERAMIC CHIP	0.01uF	10%	16V	C1036	1-125-777-11	CERAMIC CHIP	0.1uF	10%	10V
C803	1-164-943-81	CERAMIC CHIP	0.01uF	10%	16V	C1101	1-165-989-11	CERAMIC CHIP	10uF	10%	6.3V
C804	1-164-943-81	CERAMIC CHIP	0.01uF	10%	16V	C1103	1-125-777-11	CERAMIC CHIP	0.1uF	10%	10V
C805	1-164-943-81	CERAMIC CHIP	0.01uF	10%	16V	C1104	1-125-777-11	CERAMIC CHIP	0.1uF	10%	10V
C806	1-125-777-11	CERAMIC CHIP	0.1uF	10%	10V	C1108	1-125-777-11	CERAMIC CHIP	0.1uF	10%	10V
C807	1-164-848-11	CERAMIC CHIP	8PF	0.5PF	50V	C1109	1-125-777-11	CERAMIC CHIP	0.1uF	10%	10V
C808	1-164-848-11	CERAMIC CHIP	8PF	0.5PF	50V	C1110	1-125-777-11	CERAMIC CHIP	0.1uF	10%	10V
C809	1-125-777-11	CERAMIC CHIP	0.1uF	10%	10V	C1112	1-125-777-11	CERAMIC CHIP	0.1uF	10%	10V
C810	1-125-777-11	CERAMIC CHIP	0.1uF	10%	10V	C1113	1-125-777-11	CERAMIC CHIP	0.1uF	10%	10V
C811	1-805-216-21	VARISTOR, CHIP				C1114	1-164-943-81	CERAMIC CHIP	0.01uF	10%	16V
C812	1-805-216-21	VARISTOR, CHIP				C1115	1-164-943-81	CERAMIC CHIP	0.01uF	10%	16V
C813	1-805-216-21	VARISTOR, CHIP				C1120	1-165-989-11	CERAMIC CHIP	10uF	10%	6.3V
C954	1-165-989-11	CERAMIC CHIP	10uF	10%	6.3V	C1121	1-125-777-11	CERAMIC CHIP	0.1uF	10%	10V
C955	1-165-989-11	CERAMIC CHIP	10uF	10%	6.3V	C1124	1-125-777-11	CERAMIC CHIP	0.1uF	10%	10V
C956	1-165-989-11	CERAMIC CHIP	10uF	10%	6.3V	C1125	1-125-777-11	CERAMIC CHIP	0.1uF	10%	10V
C957	1-125-777-11	CERAMIC CHIP	0.1uF	10%	10V	C1200	1-125-777-11	CERAMIC CHIP	0.1uF	10%	10V
C958	1-125-777-11	CERAMIC CHIP	0.1uF	10%	10V	C1202	1-125-777-11	CERAMIC CHIP	0.1uF	10%	10V
C959	1-125-777-11	CERAMIC CHIP	0.1uF	10%	10V	C1203	1-125-777-11	CERAMIC CHIP	0.1uF	10%	10V
C960	1-125-777-11	CERAMIC CHIP	0.1uF	10%	10V	C1204	1-125-777-11	CERAMIC CHIP	0.1uF	10%	10V
C961	1-125-777-11	CERAMIC CHIP	0.1uF	10%	10V	C1205	1-164-937-11	CERAMIC CHIP	0.001uF	10%	50V
C962	1-125-777-11	CERAMIC CHIP	0.1uF	10%	10V	C1206	1-125-777-11	CERAMIC CHIP	0.1uF	10%	10V
C963	1-125-777-11	CERAMIC CHIP	0.1uF	10%	10V	C1208	1-125-777-11	CERAMIC CHIP	0.1uF	10%	10V
C964	1-125-777-11	CERAMIC CHIP	0.1uF	10%	10V	C1209	1-164-937-11	CERAMIC CHIP	0.001uF	10%	50V
C965	1-164-854-11	CERAMIC CHIP	15PF	5%	50V	C1211	1-125-777-11	CERAMIC CHIP	0.1uF	10%	10V
C966	1-164-856-81	CERAMIC CHIP	18PF	5%	50V	C1213	1-125-777-11	CERAMIC CHIP	0.1uF	10%	10V
C967	1-100-352-91	CERAMIC CHIP	1uF	20%	16V	C1214	1-125-777-11	CERAMIC CHIP	0.1uF	10%	10V
C968	1-164-943-81	CERAMIC CHIP	0.01uF	10%	16V	C1217	1-164-937-11	CERAMIC CHIP	0.001uF	10%	50V
C969	1-125-777-11	CERAMIC CHIP	0.1uF	10%	10V	C1218	1-125-777-11	CERAMIC CHIP	0.1uF	10%	10V
C970	1-125-777-11	CERAMIC CHIP	0.1uF	10%	10V	C1219	1-165-989-11	CERAMIC CHIP	10uF	10%	6.3V
C1003	1-110-569-11	TANTALUM CHIP	47uF	20%	6.3V	C1220	1-165-989-11	CERAMIC CHIP	10uF	10%	6.3V
C1004	1-125-777-11	CERAMIC CHIP	0.1uF	10%	10V	C1221	1-125-777-11	CERAMIC CHIP	0.1uF	10%	10V
C1005	1-128-964-91	TANTALUM CHIP	100uF	20%	6.3V	C1801	1-164-939-11	CERAMIC CHIP	0.0022uF	10%	50V
C1006	1-125-777-11	CERAMIC CHIP	0.1uF	10%	10V	C1804	1-100-703-91	CERAMIC CHIP	10uF	10%	25V
C1007	1-125-777-11	CERAMIC CHIP	0.1uF	10%	10V	C1805	1-100-703-91	CERAMIC CHIP	10uF	10%	25V
C1008	1-125-777-11	CERAMIC CHIP	0.1uF	10%	10V	C1806	1-100-703-91	CERAMIC CHIP	10uF	10%	25V
C1009	1-125-777-11	CERAMIC CHIP	0.1uF	10%	10V	C1808	1-104-913-11	TANTALUM CHIP	10uF	20%	16V
C1010	1-125-777-11	CERAMIC CHIP	0.1uF	10%	10V	C1809	1-104-913-11	TANTALUM CHIP	10uF	20%	16V
C1011	1-125-777-11	CERAMIC CHIP	0.1uF	10%	10V	C1810	1-100-352-91	CERAMIC CHIP	1uF	20%	16V

MAIN

Ref. No.	Part No.	Description	Remark
C1812	1-165-887-91	CERAMIC CHIP 0.22uF 10%	6.3V
C1814	1-100-162-91	CERAMIC CHIP 1uF	50V
C1816	1-164-005-11	CERAMIC CHIP 0.47uF	25V
C1818	1-100-162-91	CERAMIC CHIP 1uF	50V
C1819	1-125-777-11	CERAMIC CHIP 0.1uF 10%	10V
C1821	1-164-156-11	CERAMIC CHIP 0.1uF	25V
C1822	1-164-156-11	CERAMIC CHIP 0.1uF	25V
C1823	1-125-777-11	CERAMIC CHIP 0.1uF 10%	10V
C1834	1-100-352-91	CERAMIC CHIP 1uF 20%	16V
C1835	1-100-415-91	CERAMIC CHIP 0.47uF 10%	6.3V
C1842	1-100-505-11	CERAMIC CHIP 0.1uF 20%	16V
C1843	1-100-505-11	CERAMIC CHIP 0.1uF 20%	16V
C1844	1-100-505-11	CERAMIC CHIP 0.1uF 20%	16V
C1845	1-164-156-11	CERAMIC CHIP 0.1uF	25V
C1855	1-164-156-11	CERAMIC CHIP 0.1uF	25V
C1866	1-128-964-91	TANTALUM CHIP 100uF 20%	6.3V
C1879	1-100-567-81	CERAMIC CHIP 0.01uF 10%	25V
C1884	1-164-156-11	CERAMIC CHIP 0.1uF	25V
C1885	1-164-156-11	CERAMIC CHIP 0.1uF	25V
< CONNECTOR >			
CN201	1-784-625-31	CONNECTOR, FFC/FPC (ZIF) AN 30P	
* CN302	1-817-544-71	CONNECTOR, FPC (ZIF) 39P	
CN401	1-770-619-11	PIN, CONNECTOR 2P	
CN801	1-821-557-31	CONNECTOR, FFC/FPC (ZIF) 12P	
CN901	1-821-558-61	CONNECTOR, FFC/FPC (ZIF) 18P	
< DIODE >			
D101	8-719-069-55	DIODE UDZSNPTE-175.6B	
D102	8-719-069-55	DIODE UDZSNPTE-175.6B	
D401	8-719-989-03	DIODE DAN222	
D402	8-719-069-55	DIODE UDZSNPTE-175.6B	
D403	8-719-989-03	DIODE DAN222	
D420	8-719-085-70	DIODE CRS01 (TE85R)	
D802	8-719-083-42	DIODE HN2S01FU-TE85R	
D1801	6-500-823-01	DIODE BAT760-115	
D1802	8-719-024-71	DIODE 1SS362-TE85L	
D1803	6-500-823-01	DIODE BAT760-115	
D1804	6-500-823-01	DIODE BAT760-115	
D1805	8-719-024-71	DIODE 1SS362-TE85L	
D1807	8-719-024-71	DIODE 1SS362-TE85L	
D1808	8-719-056-23	DIODE MA2S111- (K8).SO	
D1809	8-719-056-23	DIODE MA2S111- (K8).SO	
D1810	8-719-056-48	DIODE 1SS388 (TPL3)	
D1813	8-719-024-71	DIODE 1SS362-TE85L	
< IC >			
IC101	6-702-290-01	IC AK4365VN-L	
IC107	6-706-492-01	IC TC7SHU04FU (T5RSOJF)	
IC108	6-706-487-01	IC TC7SH08FU (T5RSOYJF)	
IC201	6-709-523-01	IC R5C807	
IC202	6-706-487-01	IC TC7SH08FU (T5RSOYJF)	
IC203	6-711-467-01	IC TC74LCX138FK (EL, K)	
IC204	6-708-467-01	IC XC6213B312NR	
IC205	6-708-467-01	IC XC6213B312NR	
IC206	8-759-592-49	IC TC7SZ125FU (TE85R)	
IC301	(Not supplied)	IC A3P125-VQG100	
IC302	6-711-802-01	IC XC6215B152NR	
IC303	6-708-472-01	IC XC6215B312NR	
IC401	6-708-160-01	IC SN412005RHRLR	
IC402	6-709-526-01	IC XC9226A296MR	

Ref. No.	Part No.	Description	Remark
IC403	6-711-801-01	IC XC9226A196MR	
IC404	6-702-148-01	IC XC61CN2702NR	
IC405	8-759-824-57	IC XC61CN3002NR	
IC406	6-709-520-01	IC XC6215B292NR	
IC407	8-759-698-31	IC TC7WH74FK (TE85R)	
IC408	6-709-522-01	IC XC61CC3202NR	
IC409	6-708-467-01	IC XC6213B312NR	
IC801	6-807-759-01	IC HD64F38004FP10V-V198	
IC802	6-705-886-01	IC XC61CN2502NR	
IC953	(Not supplied)	IC S1R72V17B00A20B	
@ IC1001	6-705-206-01	IC MC9328MXLVP20R2	
IC1002	6-706-815-01	IC TMP75AIDR	
IC1101	6-705-485-01	IC TC7MP245FK (EL)	
IC1102	6-705-485-01	IC TC7MP245FK (EL)	
IC1106	(Not supplied)	IC K9F2G08U0A-PCBOT	
IC1107	6-711-803-01	IC TC7MP01FK	
IC1108	6-600-060-01	IC TC7WZ32FK (TE85R)	
IC1112	8-759-679-53	IC SN74LVC244APWR	
IC1113	8-759-679-53	IC SN74LVC244APWR	
IC1116	8-759-592-49	IC TC7SZ125FU (TE85R)	
IC1117	8-759-592-49	IC TC7SZ125FU (TE85R)	
IC1201	(Not supplied)	IC K4M561633G-BN75T	
IC1202	(Not supplied)	IC K4M561633G-BN75T	
IC1203	(Not supplied)	IC S29AL016D90TFI020H-PRS02	
IC1802	6-705-480-01	IC LT3467ES6#TR	
IC1803	8-759-337-40	IC NJM2904V (TE2)	
IC1805	6-705-481-01	IC LT1931ES5#TR	
IC1806	8-759-675-54	IC TC7W53FK (TE85R)	
IC1807	8-759-337-40	IC NJM2904V (TE2)	
< COIL/JUMPER RESISTOR/FERRIT BEAD >			
L102	1-469-528-91	INDUCTOR 100uH	
L103	1-469-526-91	INDUCTOR 22uH	
L201	1-469-525-91	INDUCTOR 10uH	
L203	1-469-525-91	INDUCTOR 10uH	
L204	1-469-525-91	INDUCTOR 10uH	
L205	1-216-864-11	SHORT CHIP 0	
L206	1-216-864-11	SHORT CHIP 0	
L207	1-469-528-91	INDUCTOR 100uH	
L301	1-469-525-91	INDUCTOR 10uH	
L402	1-456-630-22	COIL, CHOKE 6.8uH	
L403	1-456-630-22	COIL, CHOKE 6.8uH	
L801	1-216-864-11	SHORT CHIP 0	
L951	1-469-525-91	INDUCTOR 10uH	
L952	1-469-525-91	INDUCTOR 10uH	
L953	1-469-525-91	INDUCTOR 10uH	
L1002	1-469-525-91	INDUCTOR 10uH	
L1003	1-469-525-91	INDUCTOR 10uH	
L1004	1-469-527-91	INDUCTOR 47uH	
L1101	1-469-526-91	INDUCTOR 22uH	
L1102	1-469-526-91	INDUCTOR 22uH	
L1201	1-469-526-91	INDUCTOR 22uH	
L1202	1-469-526-91	INDUCTOR 22uH	
L1803	1-469-869-21	INDUCTOR (EMI FERRITE) (2012)	
L1804	1-469-869-21	INDUCTOR (EMI FERRITE) (2012)	
L1811	1-419-627-11	COIL, CHOKE 10uH	
L1812	1-419-627-11	COIL, CHOKE 10uH	

Note: When IC301, IC953, IC1106, IC1202 and IC1203 on the MAIN board is damaged, exchanged the new MAIN board for the MAIN board which IC damaged.

@ Replacing of IC1001 on the MAIN board in this set requires a special tool.

Ref. No.	Part No.	Description	Remark	Ref. No.	Part No.	Description	Remark
		< FUSE >		R250	1-400-827-31	BEAD, FERRITE (1005)	
△ PS401	1-576-415-21	FUSE (2A/32V)		R251	1-400-827-31	BEAD, FERRITE (1005)	
		< TRANSISTOR >		R252	1-218-990-81	SHORT CHIP 0	
Q104	6-550-254-01	TRANSISTOR 2SA1832F-GR (T3SOYF)		R253	1-400-827-31	BEAD, FERRITE (1005)	
Q105	8-729-037-52	TRANSISTOR 2SD2216J-QR (TX).SO		R254	1-400-827-31	BEAD, FERRITE (1005)	
Q401	8-729-037-52	TRANSISTOR 2SD2216J-QR (TX).SO		R255	1-218-985-11	RES-CHIP 470K	5% 1/16W
Q402	6-550-354-01	TRANSISTOR RTQ035P02TR		R301	1-218-990-81	SHORT CHIP 0	
Q403	6-550-254-01	TRANSISTOR 2SA1832F-GR (T3SOYF)		R302	1-218-985-11	RES-CHIP 470K	5% 1/16W
Q405	8-729-037-52	TRANSISTOR 2SD2216J-QR (TX).SO		R303	1-218-990-81	SHORT CHIP 0	
Q406	8-729-054-48	TRANSISTOR UP04601008S0		R322	1-218-985-11	RES-CHIP 470K	5% 1/16W
Q472	8-729-047-68	FET SSM3K03FE (TPL3)		R326	1-218-990-81	SHORT CHIP 0	
Q801	6-550-747-01	FET 3LP01S-K-TL-E		R327	1-218-990-81	SHORT CHIP 0	
Q802	8-729-047-68	FET SSM3K03FE (TPL3)		R328	1-218-990-81	SHORT CHIP 0	
Q1001	8-729-037-52	TRANSISTOR 2SD2216J-QR (TX).SO		R330	1-218-990-81	SHORT CHIP 0	
Q1802	8-729-037-52	TRANSISTOR 2SD2216J-QR (TX).SO		R333	1-218-947-11	RES-CHIP 330	5% 1/16W
Q1804	6-550-761-01	TRANSISTOR SSM6J07FU (TE85R)		R334	1-218-941-81	RES-CHIP 100	5% 1/16W
Q1805	8-729-037-52	TRANSISTOR 2SD2216J-QR (TX).SO		R337	1-218-947-11	RES-CHIP 330	5% 1/16W
Q1806	8-729-037-52	TRANSISTOR 2SD2216J-QR (TX).SO		R349	1-218-941-81	RES-CHIP 100	5% 1/16W
Q1809	6-550-254-01	TRANSISTOR 2SA1832F-GR (T3SOYF)		R355	1-218-990-81	SHORT CHIP 0	
Q1814	8-729-054-48	TRANSISTOR UP04601008S0		R364	1-218-953-11	RES-CHIP 1K	5% 1/16W
Q1822	8-729-023-89	FET 2SJ305 (TE85L)		R365	1-218-990-81	SHORT CHIP 0	
		< RESISTOR/FERRITE BEAD/THERMISTOR >		R376	1-218-990-81	SHORT CHIP 0	
R101	1-218-977-11	RES-CHIP 100K	5% 1/16W	R377	1-218-990-81	SHORT CHIP 0	
R102	1-218-989-11	RES-CHIP 1M	5% 1/16W	R378	1-218-990-81	SHORT CHIP 0	
R103	1-218-961-11	RES-CHIP 4.7K	5% 1/16W	R379	1-218-990-81	SHORT CHIP 0	
R104	1-218-961-11	RES-CHIP 4.7K	5% 1/16W	R380	1-218-990-81	SHORT CHIP 0	
R106	1-218-965-11	RES-CHIP 10K	5% 1/16W	R381	1-218-990-81	SHORT CHIP 0	
R107	1-218-929-11	RES-CHIP 10	5% 1/16W	R382	1-218-990-81	SHORT CHIP 0	
R108	1-218-929-11	RES-CHIP 10	5% 1/16W	R383	1-218-990-81	SHORT CHIP 0	
R109	1-218-929-11	RES-CHIP 10	5% 1/16W	R384	1-218-990-81	SHORT CHIP 0	
R110	1-218-949-11	RES-CHIP 470	5% 1/16W	R385	1-218-990-81	SHORT CHIP 0	
R116	1-218-947-11	RES-CHIP 330	5% 1/16W	R386	1-218-990-81	SHORT CHIP 0	
R117	1-218-941-81	RES-CHIP 100	5% 1/16W	R387	1-218-953-11	RES-CHIP 1K	5% 1/16W
* R120	1-469-230-21	BEAD, FERRITE (1005)		R388	1-218-953-11	RES-CHIP 1K	5% 1/16W
* R122	1-469-230-21	BEAD, FERRITE (1005)		R389	1-218-953-11	RES-CHIP 1K	5% 1/16W
R129	1-400-244-11	BEAD, FERRITE (CHIP) (1608)		R402	1-218-977-11	RES-CHIP 100K	5% 1/16W
R203	1-218-990-81	SHORT CHIP 0		R403	1-218-977-11	RES-CHIP 100K	5% 1/16W
R204	1-218-990-81	SHORT CHIP 0		R404	1-218-973-11	RES-CHIP 47K	5% 1/16W
R205	1-218-990-81	SHORT CHIP 0		R405	1-208-720-11	METAL CHIP 36K	0.5% 1/16W
R206	1-218-953-11	RES-CHIP 1K	5% 1/16W	R406	1-208-703-11	METAL CHIP 6.8K	0.5% 1/16W
R207	1-218-945-11	RES-CHIP 220	5% 1/16W	R407	1-208-911-11	METAL CHIP 10K	0.5% 1/16W
R208	1-218-945-11	RES-CHIP 220	5% 1/16W	R408	1-218-985-11	RES-CHIP 470K	5% 1/16W
R209	1-218-990-81	SHORT CHIP 0		R409	1-218-990-81	SHORT CHIP 0	
R210	1-218-941-81	RES-CHIP 100	5% 1/16W	R411	1-218-990-81	SHORT CHIP 0	
R219	1-218-977-11	RES-CHIP 100K	5% 1/16W	R413	1-218-981-91	RES-CHIP 220K	5% 1/16W
R223	1-218-941-81	RES-CHIP 100	5% 1/16W	R414	1-218-981-91	RES-CHIP 220K	5% 1/16W
R224	1-218-985-11	RES-CHIP 470K	5% 1/16W	R415	1-218-973-11	RES-CHIP 47K	5% 1/16W
R240	1-400-827-31	BEAD, FERRITE (1005)		R416	1-218-985-11	RES-CHIP 470K	5% 1/16W
R241	1-400-827-31	BEAD, FERRITE (1005)		R417	1-218-985-11	RES-CHIP 470K	5% 1/16W
R242	1-400-827-31	BEAD, FERRITE (1005)		R418	1-218-961-11	RES-CHIP 4.7K	5% 1/16W
R243	1-400-827-31	BEAD, FERRITE (1005)		R419	1-218-977-11	RES-CHIP 100K	5% 1/16W
R244	1-400-827-31	BEAD, FERRITE (1005)		R420	1-218-985-11	RES-CHIP 470K	5% 1/16W
R245	1-400-827-31	BEAD, FERRITE (1005)		R421	1-208-691-11	METAL CHIP 2.2K	0.5% 1/16W
R246	1-218-990-81	SHORT CHIP 0		R422	1-218-990-81	SHORT CHIP 0	
R247	1-218-990-81	SHORT CHIP 0		R423	1-218-977-11	RES-CHIP 100K	5% 1/16W
R248	1-400-827-31	BEAD, FERRITE (1005)		R424	1-218-985-11	RES-CHIP 470K	5% 1/16W
R249	1-400-827-31	BEAD, FERRITE (1005)		R425	1-218-965-11	RES-CHIP 10K	5% 1/16W
				R426	1-218-965-11	RES-CHIP 10K	5% 1/16W
				R427	1-218-945-11	RES-CHIP 220	5% 1/16W
				R428	1-218-977-11	RES-CHIP 100K	5% 1/16W

MAIN

Ref. No.	Part No.	Description			Remark	Ref. No.	Part No.	Description			Remark
R429	1-220-804-11	RES-CHIP	2.2M	5%	1/16W	R1821	1-208-935-11	METAL CHIP	100K	0.5%	1/16W
R430	1-218-977-11	RES-CHIP	100K	5%	1/16W	R1823	1-208-920-81	METAL CHIP	24K	0.5%	1/16W
R431	1-218-985-11	RES-CHIP	470K	5%	1/16W	R1824	1-208-933-11	METAL CHIP	82K	0.5%	1/16W
R475	1-218-969-11	RES-CHIP	22K	5%	1/16W	R1826	1-208-912-11	METAL CHIP	11K	0.5%	1/16W
R477	1-218-985-11	RES-CHIP	470K	5%	1/16W	R1827	1-208-934-11	METAL CHIP	91K	0.5%	1/16W
R801	1-218-965-11	RES-CHIP	10K	5%	1/16W	R1828	1-208-922-11	METAL CHIP	30K	0.5%	1/16W
R802	1-218-965-11	RES-CHIP	10K	5%	1/16W	R1829	1-208-683-11	METAL CHIP	1K	0.5%	1/16W
R803	1-218-941-81	RES-CHIP	100	5%	1/16W	R1832	1-208-683-11	METAL CHIP	1K	0.5%	1/16W
R804	1-218-941-81	RES-CHIP	100	5%	1/16W	R1835	1-208-711-11	METAL CHIP	15K	0.5%	1/16W
R805	1-218-941-81	RES-CHIP	100	5%	1/16W	R1836	1-218-970-11	RES-CHIP	27K	5%	1/16W
R806	1-218-985-11	RES-CHIP	470K	5%	1/16W	R1837	1-208-668-11	METAL CHIP	240	0.5%	1/16W
R807	1-218-985-11	RES-CHIP	470K	5%	1/16W	R1840	1-218-959-11	RES-CHIP	3.3K	5%	1/16W
R808	1-218-985-11	RES-CHIP	470K	5%	1/16W	R1841	1-218-961-11	RES-CHIP	4.7K	5%	1/16W
R809	1-218-985-11	RES-CHIP	470K	5%	1/16W	R1842	1-218-973-11	RES-CHIP	47K	5%	1/16W
R810	1-218-977-11	RES-CHIP	100K	5%	1/16W	R1843	1-218-965-11	RES-CHIP	10K	5%	1/16W
R811	1-218-941-81	RES-CHIP	100	5%	1/16W	R1844	1-208-922-11	METAL CHIP	30K	0.5%	1/16W
R812	1-218-990-81	SHORT CHIP	0			R1845	1-208-711-11	METAL CHIP	15K	0.5%	1/16W
R813	1-218-941-81	RES-CHIP	100	5%	1/16W	R1846	1-208-683-11	METAL CHIP	1K	0.5%	1/16W
R814	1-218-953-11	RES-CHIP	1K	5%	1/16W	R1847	1-218-989-11	RES-CHIP	1M	5%	1/16W
R815	1-218-985-11	RES-CHIP	470K	5%	1/16W	R1848	1-218-977-11	RES-CHIP	100K	5%	1/16W
R816	1-218-953-11	RES-CHIP	1K	5%	1/16W	R1849	1-218-953-11	RES-CHIP	1K	5%	1/16W
R817	1-218-985-11	RES-CHIP	470K	5%	1/16W	R1860	1-245-115-91	METAL CHIP	100K	0.1%	1/10W
R819	1-218-985-11	RES-CHIP	470K	5%	1/16W	R1861	1-245-115-91	METAL CHIP	100K	0.1%	1/10W
R821	1-218-985-11	RES-CHIP	470K	5%	1/16W	R1863	1-208-911-11	METAL CHIP	10K	0.5%	1/16W
R822	1-208-912-11	METAL CHIP	11K	0.5%	1/16W	R1864	1-218-987-11	RES-CHIP	680K	5%	1/16W
R824	1-218-941-81	RES-CHIP	100	5%	1/16W	R1876	1-208-911-11	METAL CHIP	10K	0.5%	1/16W
R825	1-218-965-11	RES-CHIP	10K	5%	1/16W	R1880	1-218-965-11	RES-CHIP	10K	5%	1/16W
R826	1-208-715-11	METAL CHIP	22K	0.5%	1/16W	R1881	1-218-977-11	RES-CHIP	100K	5%	1/16W
R827	1-218-977-11	RES-CHIP	100K	5%	1/16W	R1882	1-218-965-11	RES-CHIP	10K	5%	1/16W
R828	1-218-977-11	RES-CHIP	100K	5%	1/16W	R1883	1-208-911-11	METAL CHIP	10K	0.5%	1/16W
R829	1-218-959-11	RES-CHIP	3.3K	5%	1/16W	R1884	1-218-965-11	RES-CHIP	10K	5%	1/16W
R833	1-218-989-11	RES-CHIP	1M	5%	1/16W	R1885	1-218-977-11	RES-CHIP	100K	5%	1/16W
R836	1-218-985-11	RES-CHIP	470K	5%	1/16W	R1886	1-208-929-81	METAL CHIP	56K	0.5%	1/16W
R837	1-218-985-11	RES-CHIP	470K	5%	1/16W	R1887	1-208-929-81	METAL CHIP	56K	0.5%	1/16W
R840	1-218-941-81	RES-CHIP	100	5%	1/16W	R1888	1-218-977-11	RES-CHIP	100K	5%	1/16W
R842	1-218-941-81	RES-CHIP	100	5%	1/16W	R1889	1-218-965-11	RES-CHIP	10K	5%	1/16W
R851	1-218-953-11	RES-CHIP	1K	5%	1/16W	R1890	1-208-715-11	METAL CHIP	22K	0.5%	1/16W
R856	1-218-941-81	RES-CHIP	100	5%	1/16W	R1891	1-208-923-11	METAL CHIP	33K	0.5%	1/16W
R857	1-218-941-81	RES-CHIP	100	5%	1/16W	R1892	1-218-977-11	RES-CHIP	100K	5%	1/16W
R954	1-218-947-11	RES-CHIP	330	5%	1/16W	R1893	1-218-977-11	RES-CHIP	100K	5%	1/16W
R956	1-218-990-81	SHORT CHIP	0			R1894	1-208-920-81	METAL CHIP	24K	0.5%	1/16W
R957	1-218-990-81	SHORT CHIP	0			R1895	1-218-970-11	RES-CHIP	27K	5%	1/16W
R958	1-218-990-81	SHORT CHIP	0			R1898	1-218-953-11	RES-CHIP	1K	5%	1/16W
R959	1-218-977-11	RES-CHIP	100K	5%	1/16W	R1899	1-218-941-81	RES-CHIP	100	5%	1/16W
R960	1-218-977-11	RES-CHIP	100K	5%	1/16W	R1907	1-218-977-11	RES-CHIP	100K	5%	1/16W
R961	1-218-977-11	RES-CHIP	100K	5%	1/16W	R1908	1-218-977-11	RES-CHIP	100K	5%	1/16W
R962	1-208-906-81	METAL CHIP	6.2K	0.5%	1/16W	R1910	1-218-990-81	SHORT CHIP	0		
R965	1-218-929-11	RES-CHIP	10	5%	1/16W	R2010	1-218-951-11	RES-CHIP	680	5%	1/16W
R967	1-218-977-11	RES-CHIP	100K	5%	1/16W	R2013	1-218-941-81	RES-CHIP	100	5%	1/16W
R968	1-218-977-11	RES-CHIP	100K	5%	1/16W	R2019	1-218-947-11	RES-CHIP	330	5%	1/16W
R969	1-218-976-11	RES-CHIP	82K	5%	1/16W	R2020	1-218-947-11	RES-CHIP	330	5%	1/16W
R970	1-218-976-11	RES-CHIP	82K	5%	1/16W	R2021	1-218-947-11	RES-CHIP	330	5%	1/16W
R971	1-805-719-12	THERMISTOR, POSITIVE				R2101	1-218-953-11	RES-CHIP	1K	5%	1/16W
R1103	1-218-990-81	SHORT CHIP	0			R2102	1-218-953-11	RES-CHIP	1K	5%	1/16W
R1298	1-240-726-91	METAL CHIP	470K	5%	1/20W	R2103	1-218-941-81	RES-CHIP	100	5%	1/16W
R1802	1-216-864-11	SHORT CHIP	0			R2104	1-218-941-81	RES-CHIP	100	5%	1/16W
R1807	1-218-965-11	RES-CHIP	10K	5%	1/16W	R2105	1-218-929-11	RES-CHIP	10	5%	1/16W
R1814	1-218-953-11	RES-CHIP	1K	5%	1/16W	R2119	1-218-965-11	RES-CHIP	10K	5%	1/16W
R1815	1-218-987-11	RES-CHIP	680K	5%	1/16W	R2208	1-218-977-11	RES-CHIP	100K	5%	1/16W
R1816	1-218-977-11	RES-CHIP	100K	5%	1/16W	R2214	1-218-965-11	RES-CHIP	10K	5%	1/16W

Ref. No.	Part No.	Description	Remark
R2215	1-218-965-11	RES-CHIP 10K 5%	1/16W
R2216	1-218-965-11	RES-CHIP 10K 5%	1/16W
R2219	1-218-965-11	RES-CHIP 10K 5%	1/16W
R2238	1-218-965-11	RES-CHIP 10K 5%	1/16W
R2239	1-218-965-11	RES-CHIP 10K 5%	1/16W
R2264	1-218-977-11	RES-CHIP 100K 5%	1/16W
R2267	1-218-977-11	RES-CHIP 100K 5%	1/16W
R2268	1-218-977-11	RES-CHIP 100K 5%	1/16W
R2527	1-218-947-11	RES-CHIP 330 5%	1/16W
< COMPOSITION CIRCUIT BLOCK >			
RB201	1-234-372-11	RES, NETWORK 100 (1005X4)	
RB202	1-234-372-11	RES, NETWORK 100 (1005X4)	
RB203	1-234-372-11	RES, NETWORK 100 (1005X4)	
RB301	1-234-372-11	RES, NETWORK 100 (1005X4)	
RB302	1-234-372-11	RES, NETWORK 100 (1005X4)	
RB303	1-234-372-11	RES, NETWORK 100 (1005X4)	
RB304	1-234-372-11	RES, NETWORK 100 (1005X4)	
RB801	1-234-372-11	RES, NETWORK 100 (1005X4)	
RB802	1-234-372-11	RES, NETWORK 100 (1005X4)	
RB803	1-234-372-11	RES, NETWORK 100 (1005X4)	
RB804	1-234-372-11	RES, NETWORK 100 (1005X4)	
RB805	1-234-379-21	RES, NETWORK 22K (1005X4)	
RB806	1-234-379-21	RES, NETWORK 22K (1005X4)	
RB807	1-234-379-21	RES, NETWORK 22K (1005X4)	
RB808	1-234-379-21	RES, NETWORK 22K (1005X4)	
RB2001	1-234-372-11	RES, NETWORK 100 (1005X4)	
RB2002	1-234-372-11	RES, NETWORK 100 (1005X4)	
RB2003	1-234-372-11	RES, NETWORK 100 (1005X4)	
RB2004	1-234-372-11	RES, NETWORK 100 (1005X4)	
RB2005	1-234-372-11	RES, NETWORK 100 (1005X4)	
RB2006	1-234-387-21	RES, NETWORK 330 (1005X4)	
RB2007	1-234-372-11	RES, NETWORK 100 (1005X4)	
RB2008	1-234-383-21	RES, NETWORK 470K (1005X4)	
RB2009	1-234-383-21	RES, NETWORK 470K (1005X4)	
RB2010	1-234-383-21	RES, NETWORK 470K (1005X4)	
RB2011	1-234-387-21	RES, NETWORK 330 (1005X4)	
RB2012	1-234-387-21	RES, NETWORK 330 (1005X4)	
RB2013	1-234-387-21	RES, NETWORK 330 (1005X4)	
RB2014	1-234-383-21	RES, NETWORK 470K (1005X4)	
RB2015	1-234-383-21	RES, NETWORK 470K (1005X4)	
RB2016	1-234-383-21	RES, NETWORK 470K (1005X4)	
< VARIABLE RESISTOR >			
RV1801	1-225-901-21	RES, ADJ, CERMET (3 TYPE) 10K	
< SWITCH >			
S801	1-786-515-21	SWITCH, TACTILE (RESET)	
S873	1-786-293-21	SWITCH, TACTILE (VOL -)	
S874	1-786-293-21	SWITCH, TACTILE (VOL +)	
< COIL >			
T951	1-400-284-21	COIL, COMMON MODE CHOKE	
< THERMISTOR (POSITIVE) >			
THP401	1-804-949-11	THERMISTOR, NTC (SMD)	
< VIBRATOR >			
X102	1-813-180-21	VIBRATOR, CERAMIC (11.2896MHz)	

Ref. No.	Part No.	Description	Remark
X801	1-795-029-11	VIBRATOR, CRYSTAL (32.768kHz)	
X802	1-813-181-21	VIBRATOR, CERAMIC (4.9152MHz)	
X951	1-813-877-11	VIBRATOR, CRYSTAL (12MHz)	
X1002	1-795-029-11	VIBRATOR, CRYSTAL (32.768kHz)	

	A-1362-419-A	SLOT FLEXIBLE BOARD, COMPLETE	

When SLOT FLEXIBLE board is defective, exchange the entire mounted board.			

MISCELLANEOUS			

5	X-2187-666-1	CASE LC ASSY (for BLUE) (including KEY flexible board)	
5	X-2187-670-1	CASE SC ASSY (for SILVER) (including KEY flexible board)	
52	X-2187-668-1	BATTERY ASSY, (ION) STORAGE	
IIE1	X-2187-669-2	ELEMENT ASSY, INK (INDICATION)	

ACCESSORIES			

	1-829-882-12	CORD, CONNECTION (USB) (USB cable)	
	3-273-916-01	CARD (SD), DUMMY (Dummy card)	
	3-273-917-01	CARD (MS DUO), DUMMY (Dummy card)	
	3-274-631-01	GUIDE, QUICK START (ENGLISH, FRENCH)	
	3-274-632-01	SOFT, APPLICATION (CD-ROM: eBook Library software/User's Guide (PDF)/Sample Contents)	

MEMO

PRS-505

SONY

SERVICE MANUAL

Ver. 1.1 2007.12

*US Model
Canadian Model*

SUPPLEMENT-1

File this supplement with the service manual.

Subject: Change of MAIN board (Suffix-12)

In this set, MAIN board has been changed in the midway of production. Printed wiring board, schematic diagram and electrical parts list of new type are described in this supplement-1. Refer to original service manual for other information.

TABLE OF CONTENTS

1. NEW/FORMER DISCRIMINATION	1
2. DIAGRAMS	
2-1. Printed Wiring Board	
- MAIN Board (Component Side) -	3
2-2. Printed Wiring Board	
- MAIN Board (Conductor Side) -	4
2-3. Schematic Diagram - MAIN Board (1/10) -	5
2-4. Schematic Diagram - MAIN Board (2/10) -	6
2-5. Schematic Diagram - MAIN Board (3/10) -	7
2-6. Schematic Diagram - MAIN Board (4/10) -	8
2-7. Schematic Diagram - MAIN Board (5/10) -	9
2-8. Schematic Diagram - MAIN Board (6/10) -	10
2-9. Schematic Diagram - MAIN Board (7/10) -	11
2-10. Schematic Diagram - MAIN Board (8/10) -	12
2-11. Schematic Diagram - MAIN Board (9/10) -	13
2-12. Schematic Diagram - MAIN Board (10/10) -	14
3. ELECTRICAL PARTS LIST	15

1. NEW/FORMER DISCRIMINATION

– MAIN Board (Component Side) –

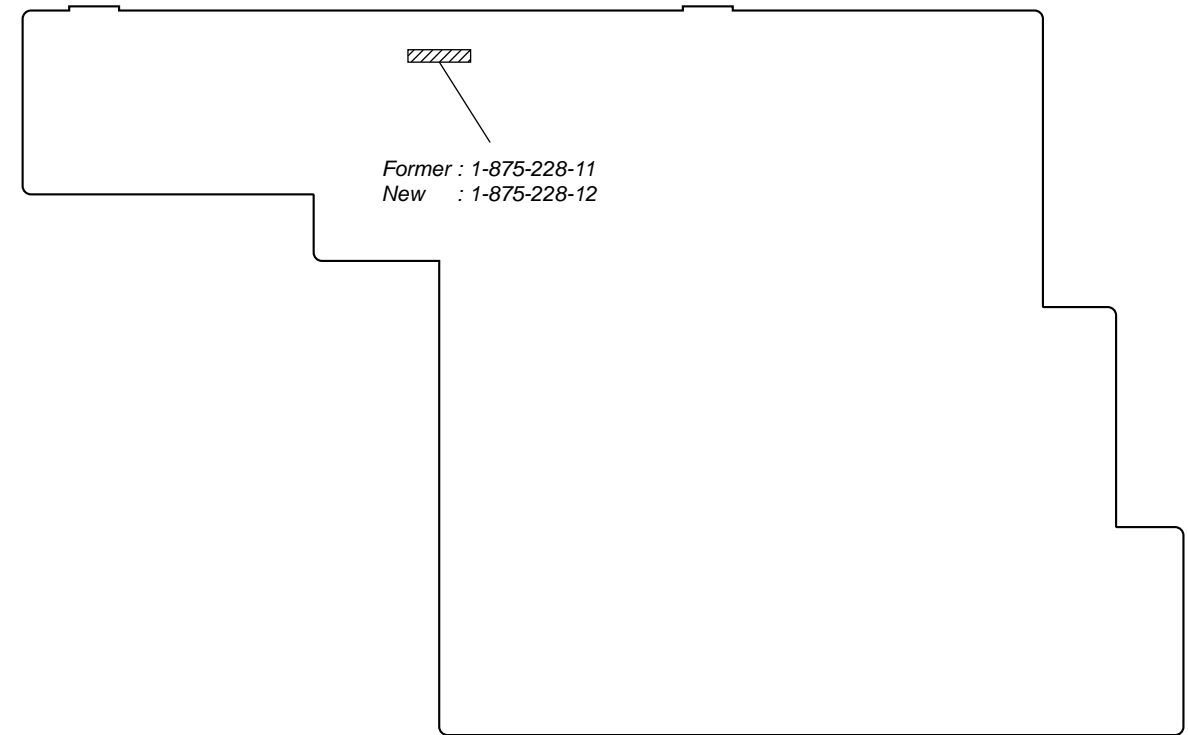

2. DIAGRAMS

THIS NOTE IS COMMON FOR PRINTED WIRING BOARDS AND SCHEMATIC DIAGRAMS.
 (In addition to this, the necessary note is printed in each block.)

For Printed Wiring Boards.

Note:

- : Parts extracted from the conductor side.
- △ : internal component.
- : Pattern from the side which enables seeing.
 (The other layers' patterns are not indicated.)

Caution:
 Parts face side: Parts on the parts face side seen from (Conductor side) the pattern face are indicated.
 Pattern face side: Parts on the pattern face side seen from (Component side) the parts face are indicated.

- MAIN board is multi-layer printed board. However, the patterns of intermediate-layers have not been included in diagrams.

* Replacing of IC1001 on the MAIN board used in this set requires a special tool.

- Lead layouts



Lead layout of conventional IC

CSP (Chip Size Package)

For Schematic Diagrams.

Note:

- All capacitors are in μF unless otherwise noted. (p: pF) 50 WV or less are not indicated except for electrolytics and tantalums.
- All resistors are in Ω and $1/4$ W or less unless otherwise specified.
- △ : internal component.
- : panel designation.

Note:
 The components identified by mark △ or dotted line with mark △ are critical for safety.
 Replace only with part number specified.

Note:
 Les composants identifiés par une marque △ sont critiques pour la sécurité.
 Ne les remplacer que par une pièce portant le numéro spécifié.

- : B+ Line.
- - - : B- Line.
- : adjustment for repair.
- Power voltage is dc 5.2V and fed with regulated dc power supply from TP402 and TP400 on the MAIN board.
- Voltages are dc with respect to ground under no-signal (detuned) conditions.
 no mark: POWER ON
 () : AUDIO PLAY
 * : Impossible to measure
 (For this model, the voltage is produced only when the screen is changed. Under the power on, there is a voltage that is not produced.)
- Voltages are taken with VOM (Input impedance 10 M Ω). Voltage variations may be noted due to normal production tolerances.
- Signal path.
 ⇨ : AUDIO
 ⇨⇨ : VIDEO
 ▽ : USB
 ▴ : SD MEMORY CARD/MEMORY STICK DUO

* Replacing of IC1001 on the MAIN board used in this set requires a special tool.

- The voltage and waveform of CSP (chip size package) cannot be measured, because its lead is different from that conventional IC.

2-1. PRINTED WIRING BOARD - MAIN Board (Component Side) -  : Uses unleaded solder.

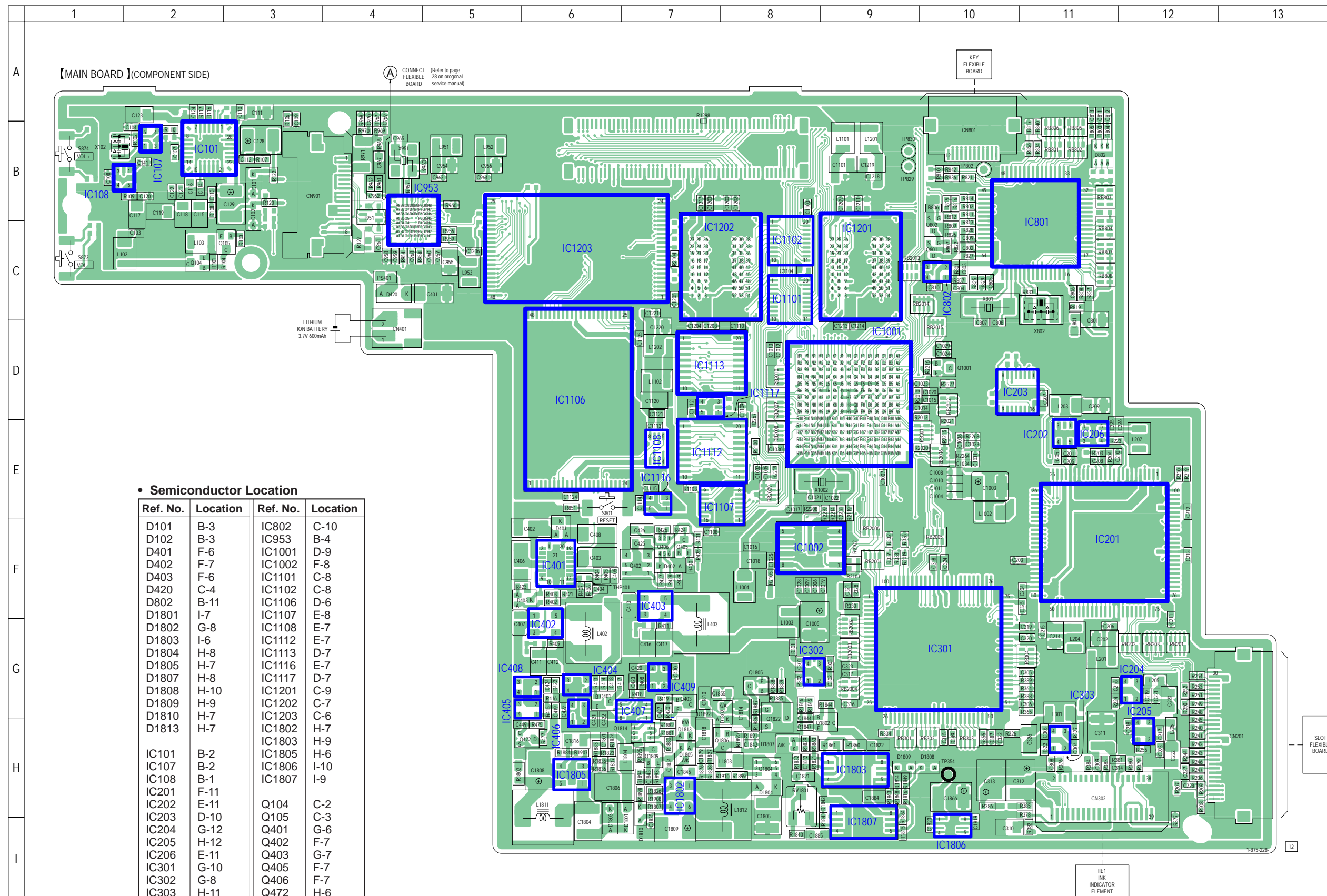

• Semiconductor Location

Ref. No.	Location	Ref. No.	Location
D101	B-3	IC802	C-10
D102	B-3	IC953	B-4
D401	F-6	IC1001	D-9
D402	F-7	IC1002	F-8
D403	F-6	IC1101	C-8
D420	C-4	IC1102	C-8
D802	B-11	IC1106	D-6
D1801	I-7	IC1107	E-8
D1802	G-8	IC1108	E-7
D1803	I-6	IC1112	E-7
D1804	H-8	IC1113	D-7
D1805	H-7	IC1116	E-7
D1807	H-8	IC1117	D-7
D1808	H-10	IC1201	C-9
D1809	H-9	IC1202	C-7
D1810	H-7	IC1203	C-6
D1813	H-7	IC1802	H-7
		IC1803	H-9
IC101	B-2	IC1805	H-6
IC107	B-2	IC1806	I-10
IC108	B-1	IC1807	I-9
IC201	F-11		
IC202	E-11	Q104	C-2
IC203	D-10	Q105	C-3
IC204	G-12	Q401	G-6
IC205	H-12	Q402	F-7
IC206	E-11	Q403	G-7
IC301	G-10	Q405	F-7
IC302	G-8	Q406	F-7
IC303	H-11	Q472	H-6
IC401	F-6	Q801	C-10
IC402	G-6	Q802	C-10
IC403	F-7	Q1001	D-10
IC404	G-6	Q1802	H-9
IC405	G-6	Q1804	H-8
IC406	G-6	Q1805	G-8
IC407	G-7	Q1806	H-8
IC408	G-6	Q1809	H-7
IC409	G-7	Q1814	H-7
IC801	C-11	Q1822	H-8

Note: When IC301, IC953, IC1106, IC1201, IC1202 and IC1203 on the MAIN board is damaged, exchange the new MAIN board for the MAIN board which IC damaged.

2-2. PRINTED WIRING BOARD - MAIN Board (Conductor Side) - •  : Uses unleaded solder.

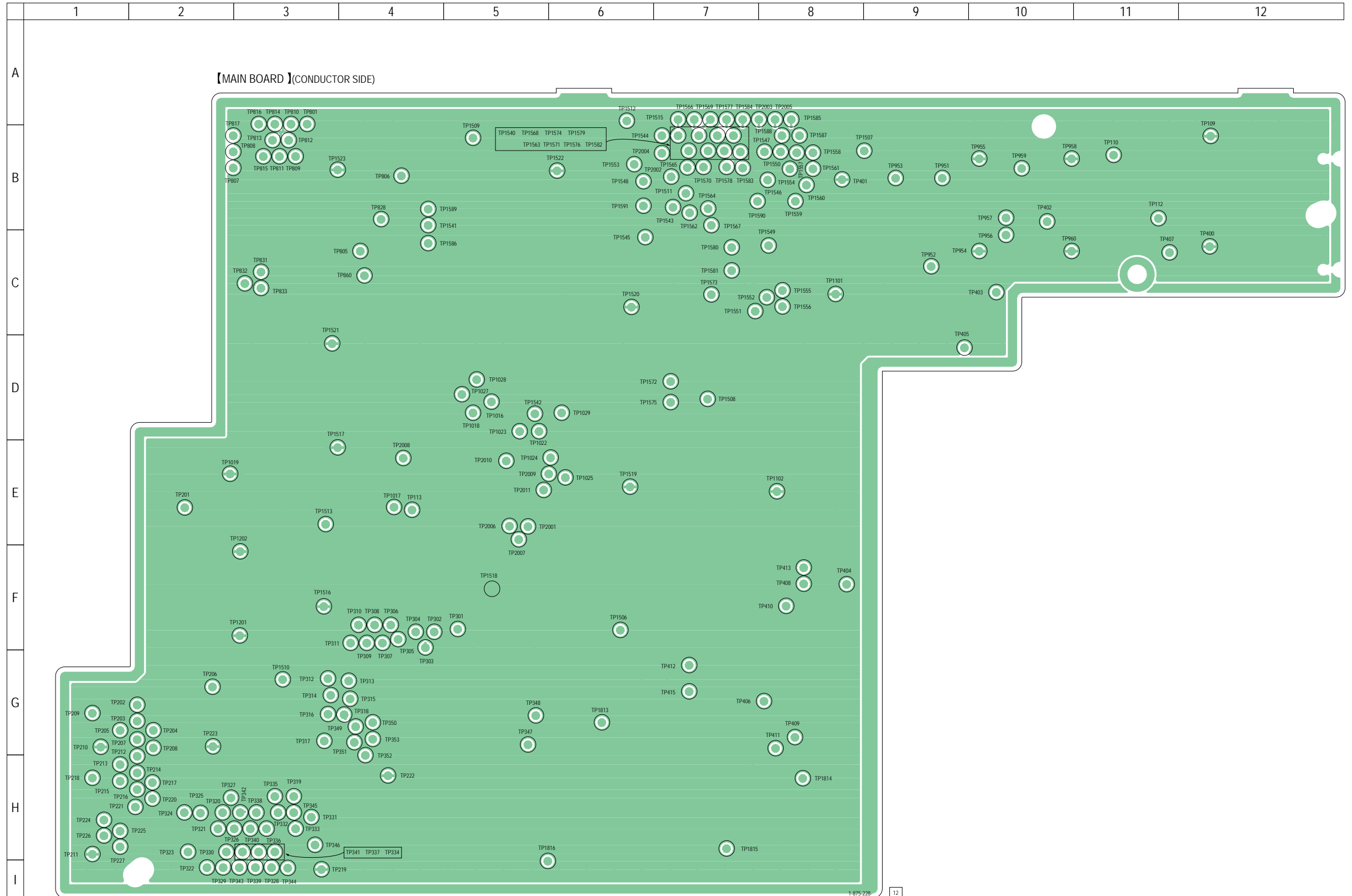

2-3. SCHEMATIC DIAGRAM - MAIN Board (1/10) -

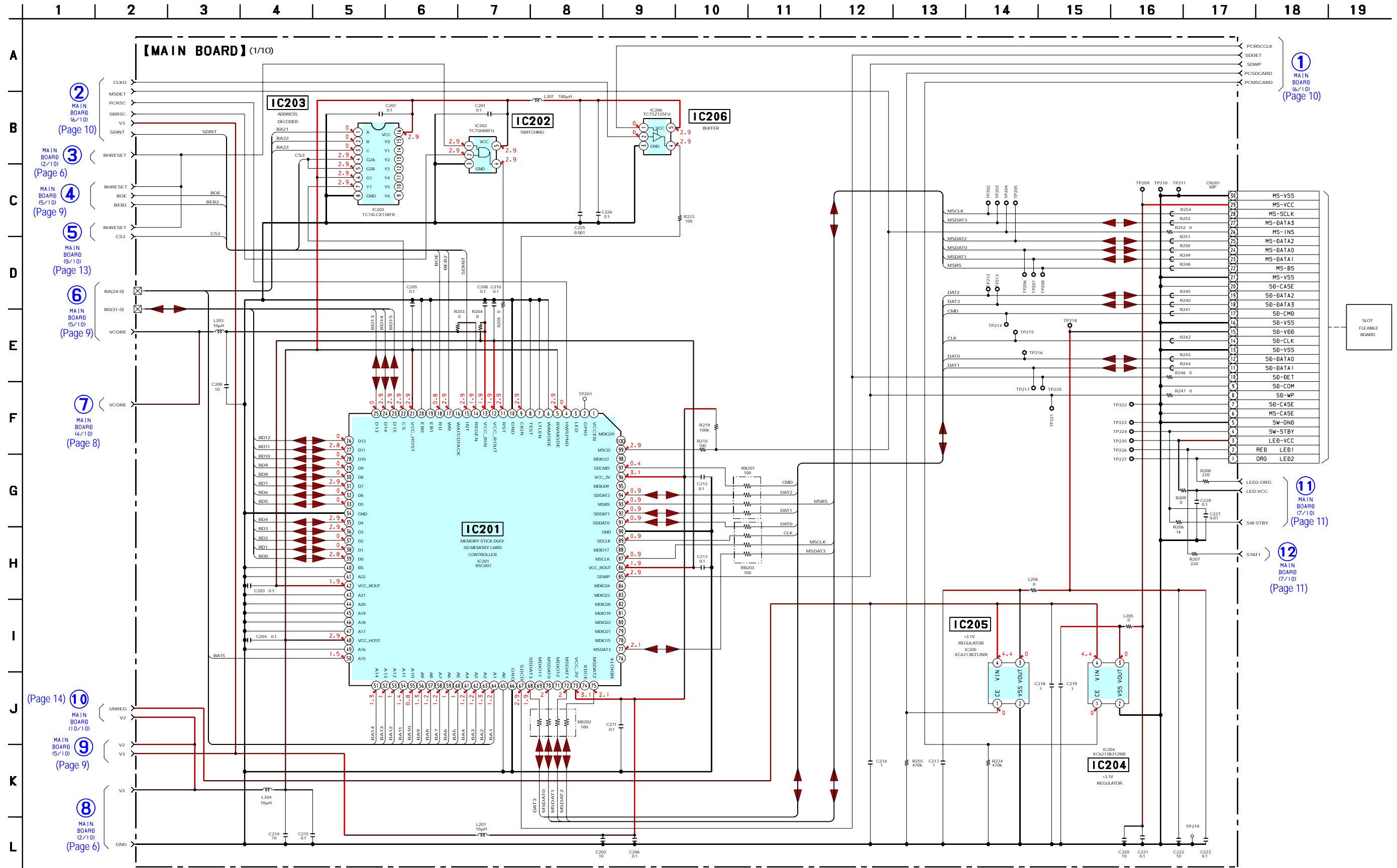

2-4. SCHEMATIC DIAGRAM - MAIN Board (2/10) -

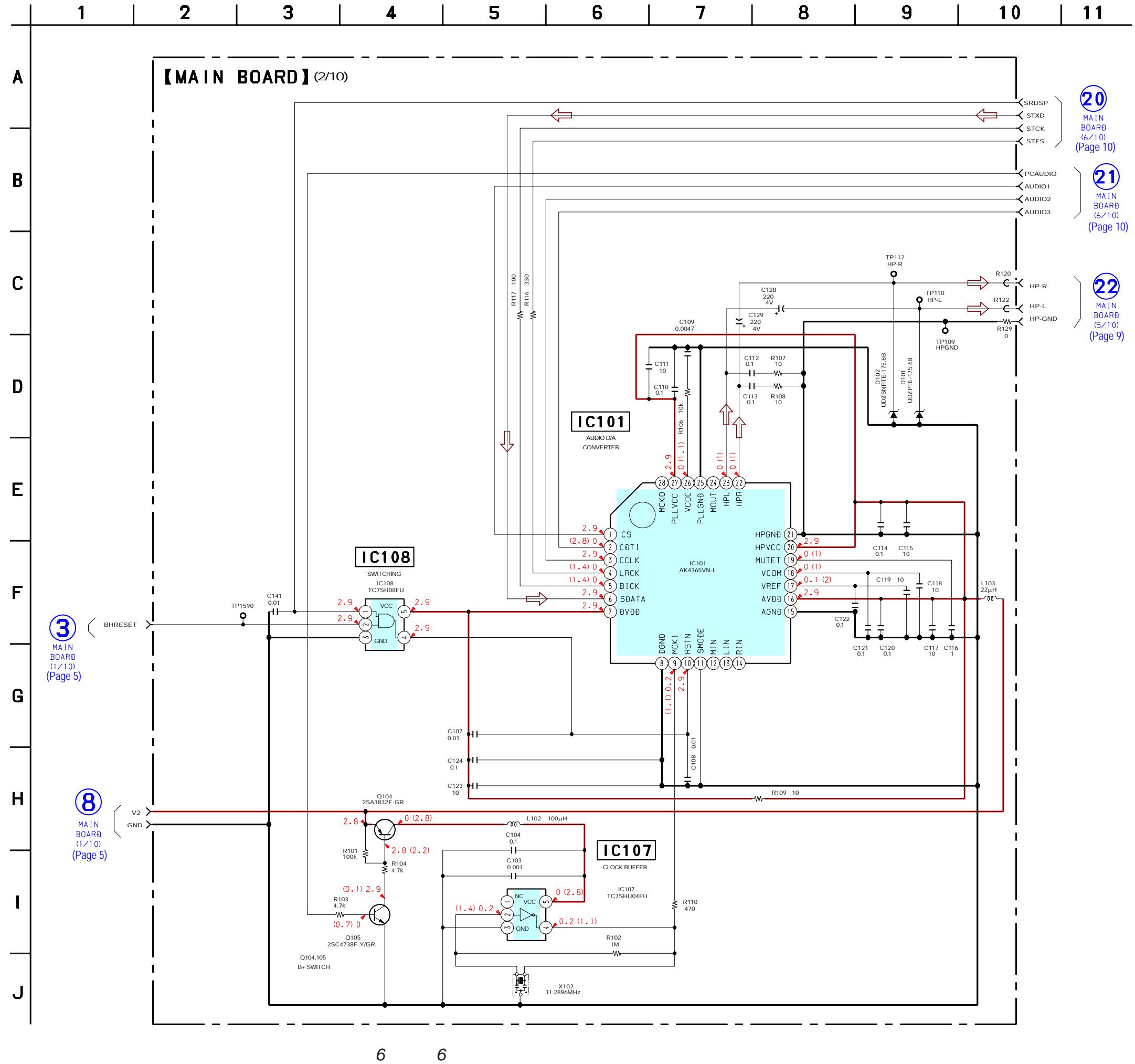

2-5. SCHEMATIC DIAGRAM - MAIN Board (3/10) -

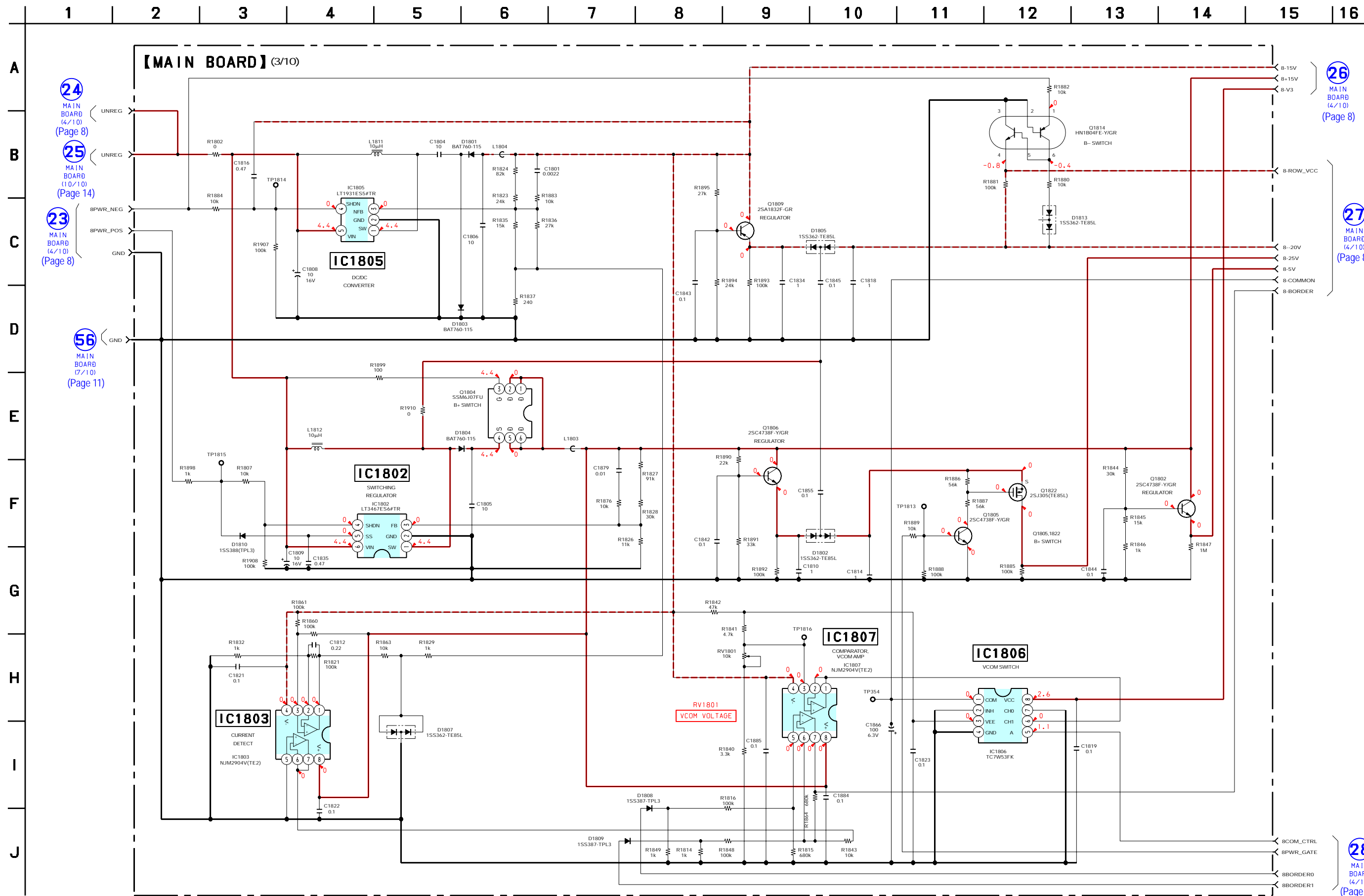

2-6. SCHEMATIC DIAGRAM - MAIN Board (4/10) -

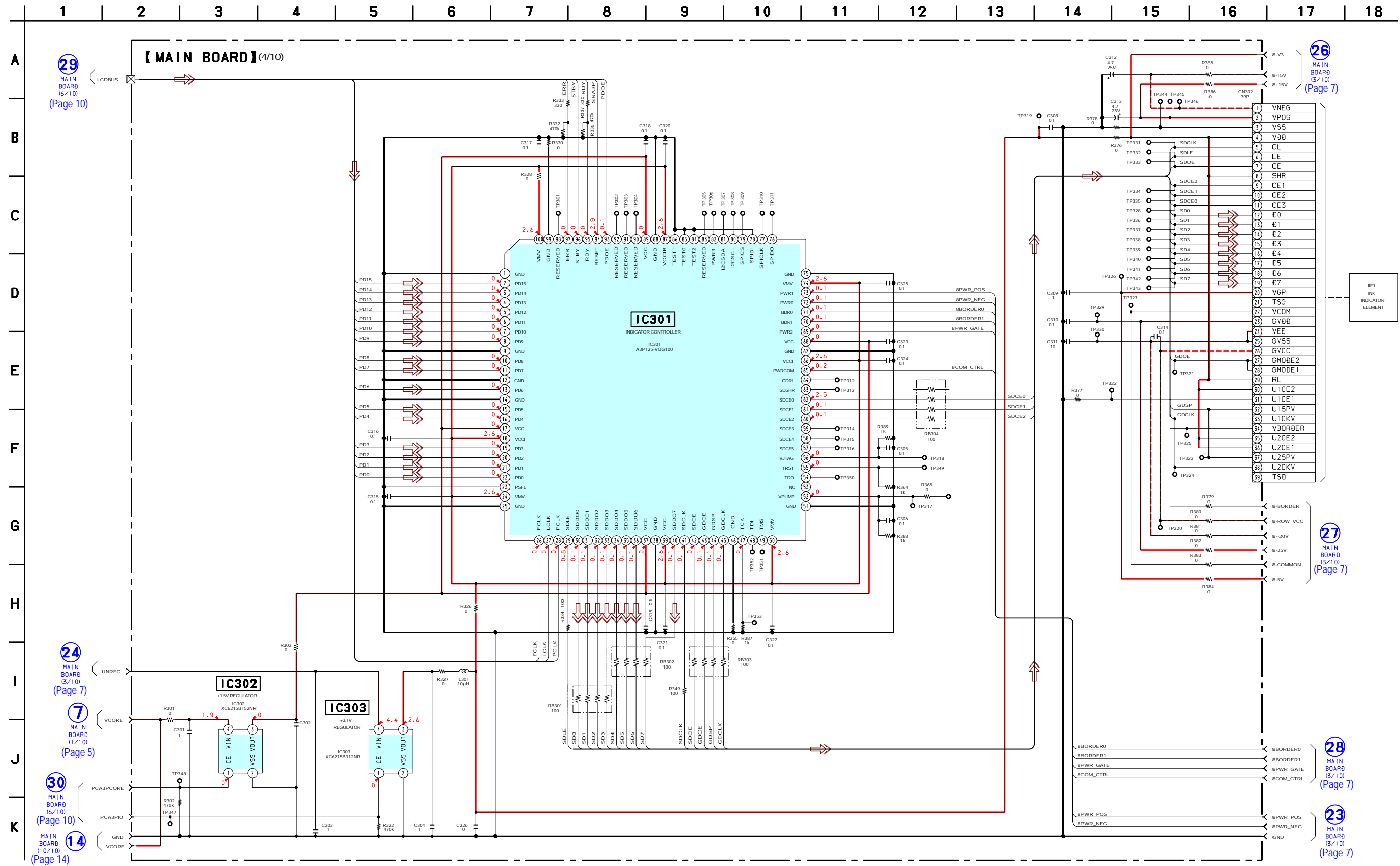

29 MAIN BOARD (6/10) (Page 10)

26 MAIN BOARD (3/10) (Page 7)

24 MAIN BOARD (3/10) (Page 7)

7 MAIN BOARD (1/10) (Page 5)

30 MAIN BOARD (6/10) (Page 10)

14 MAIN BOARD (10/10) (Page 14)

27 MAIN BOARD (3/10) (Page 7)

28 MAIN BOARD (3/10) (Page 7)

23 MAIN BOARD (3/10) (Page 7)

Note: When IC301 on the MAIN board is damaged, exchange the new MAIN board for the MAIN board which IC damaged.

2-7. SCHEMATIC DIAGRAM - MAIN Board (5/10) -

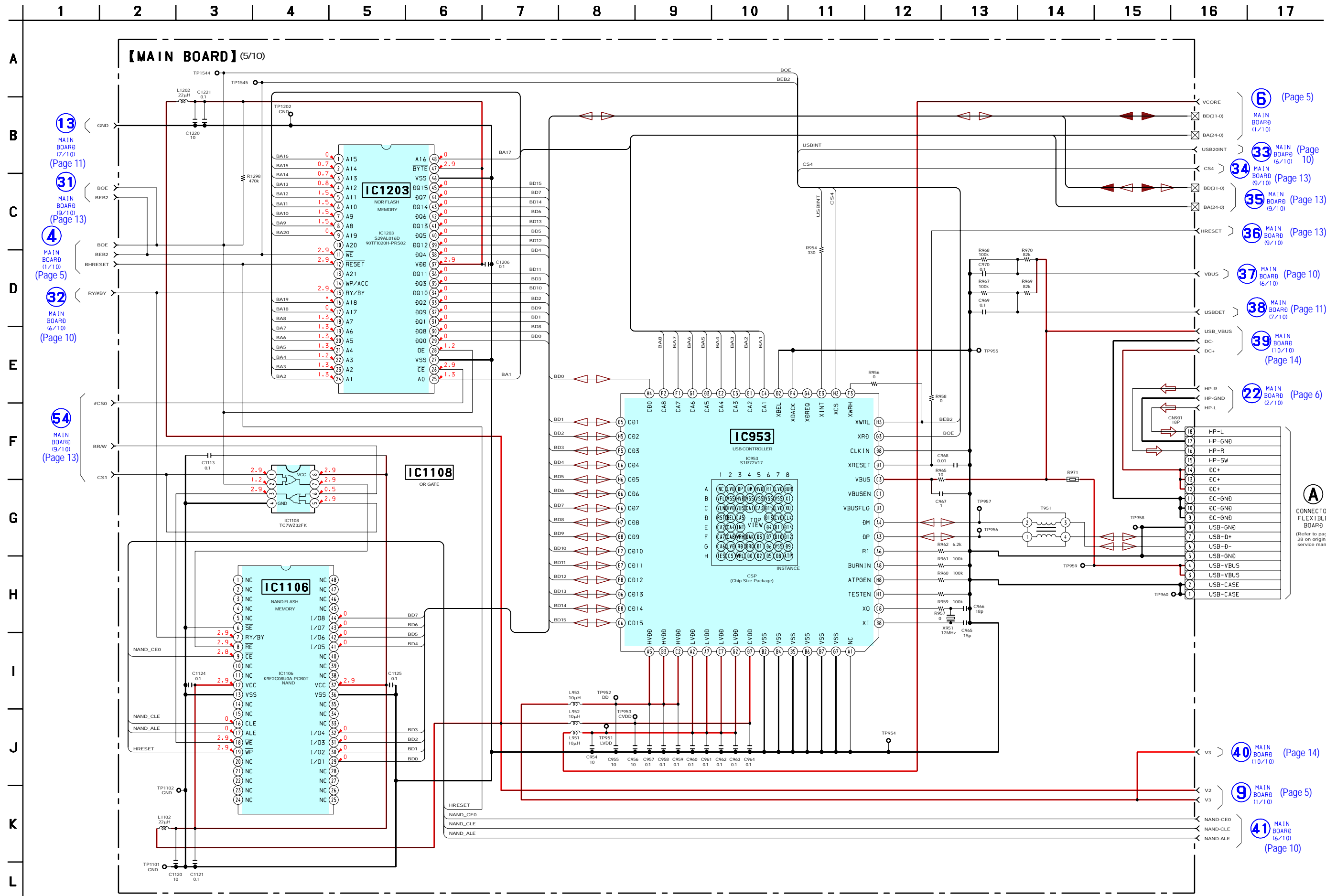

Note: When IC953, IC1106 and IC1203 on the MAIN board is damaged, exchange the new MAIN board for the MAIN board which IC damaged.

2-8. SCHEMATIC DIAGRAM - MAIN Board (6/10) -

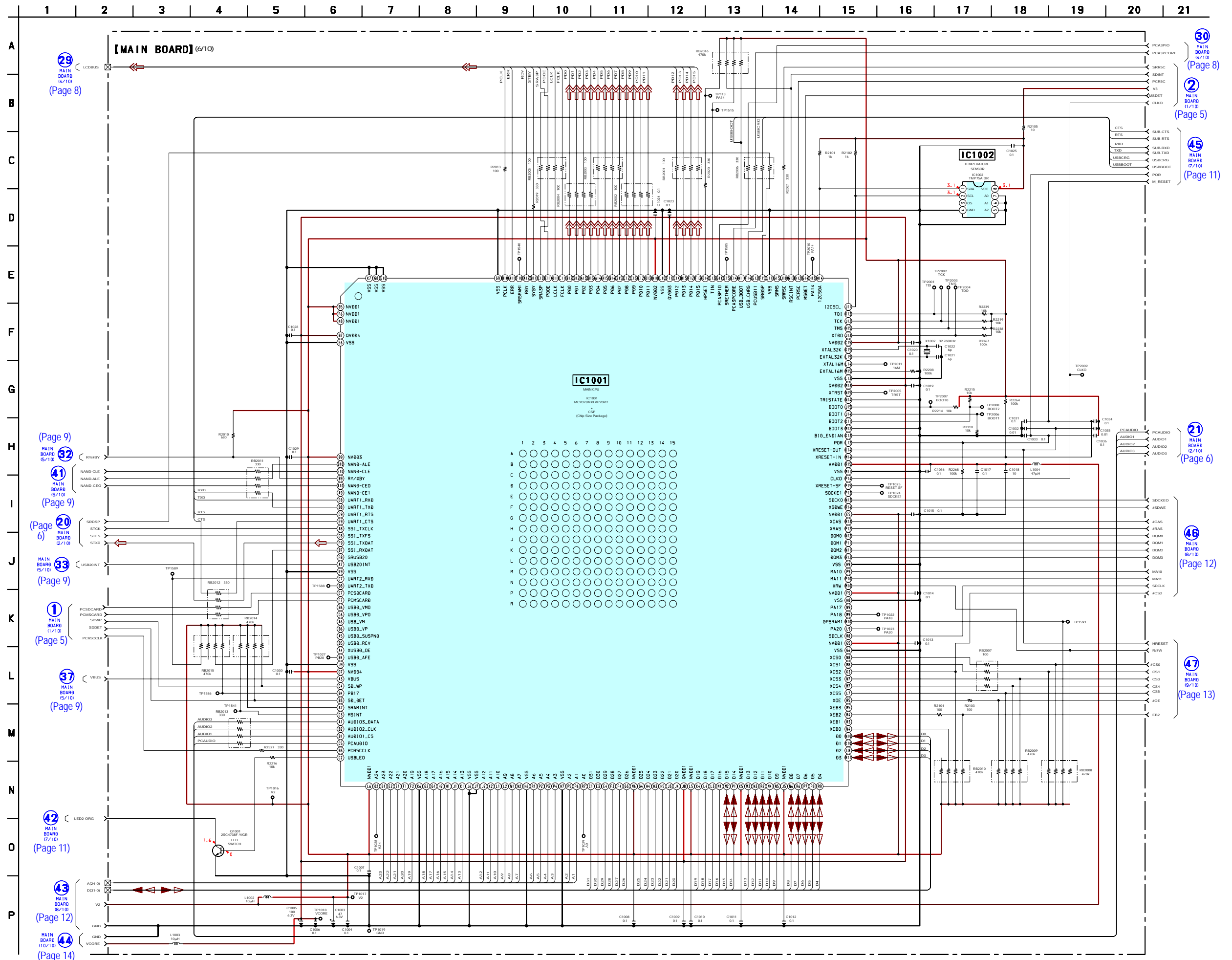

Note: Replacement of IC1001 on the MAIN board used in this set requires a special tool.

2-9. SCHEMATIC DIAGRAM - MAIN Board (7/10) -

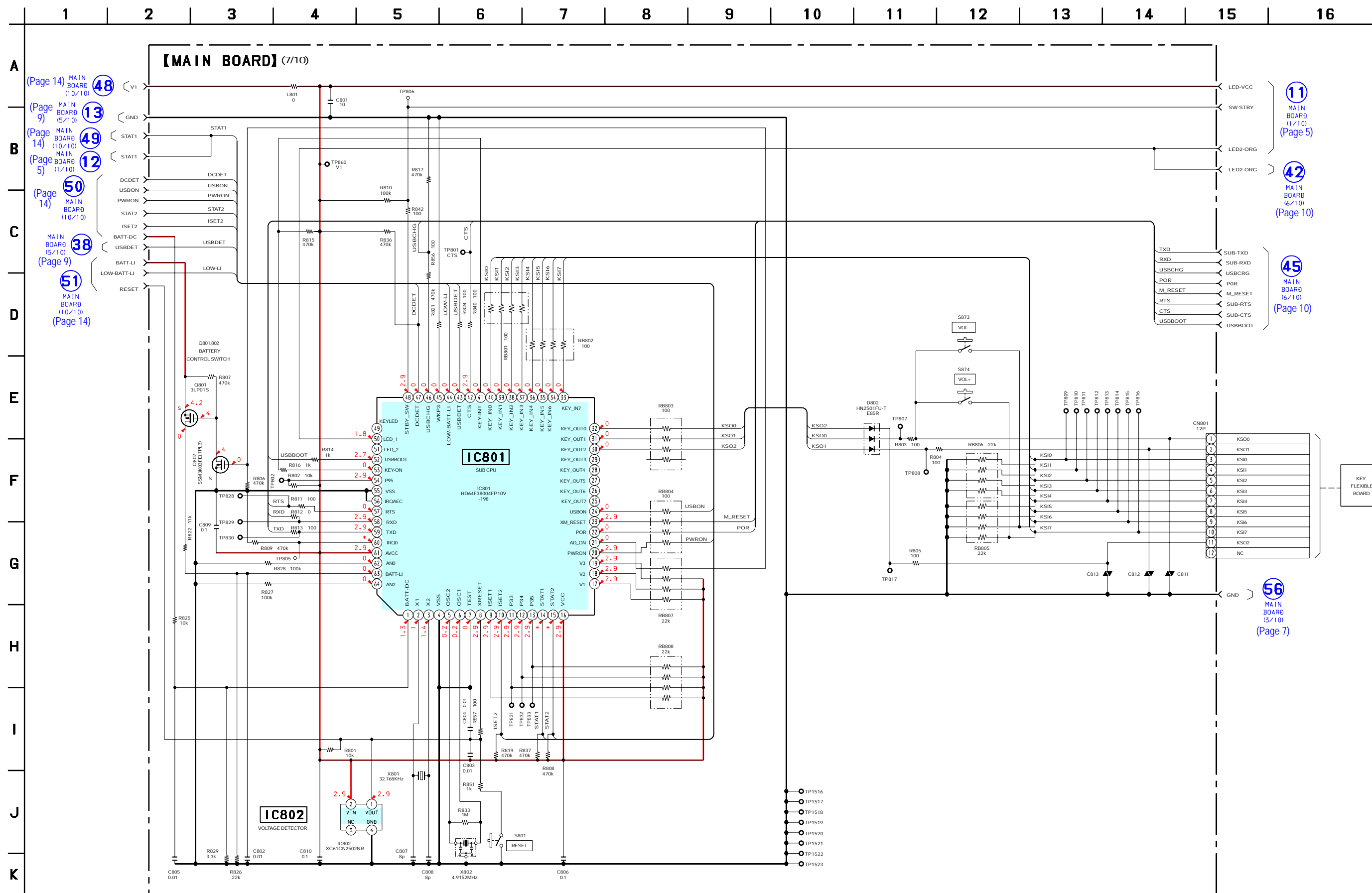

2-10. SCHEMATIC DIAGRAM - MAIN Board (8/10) -

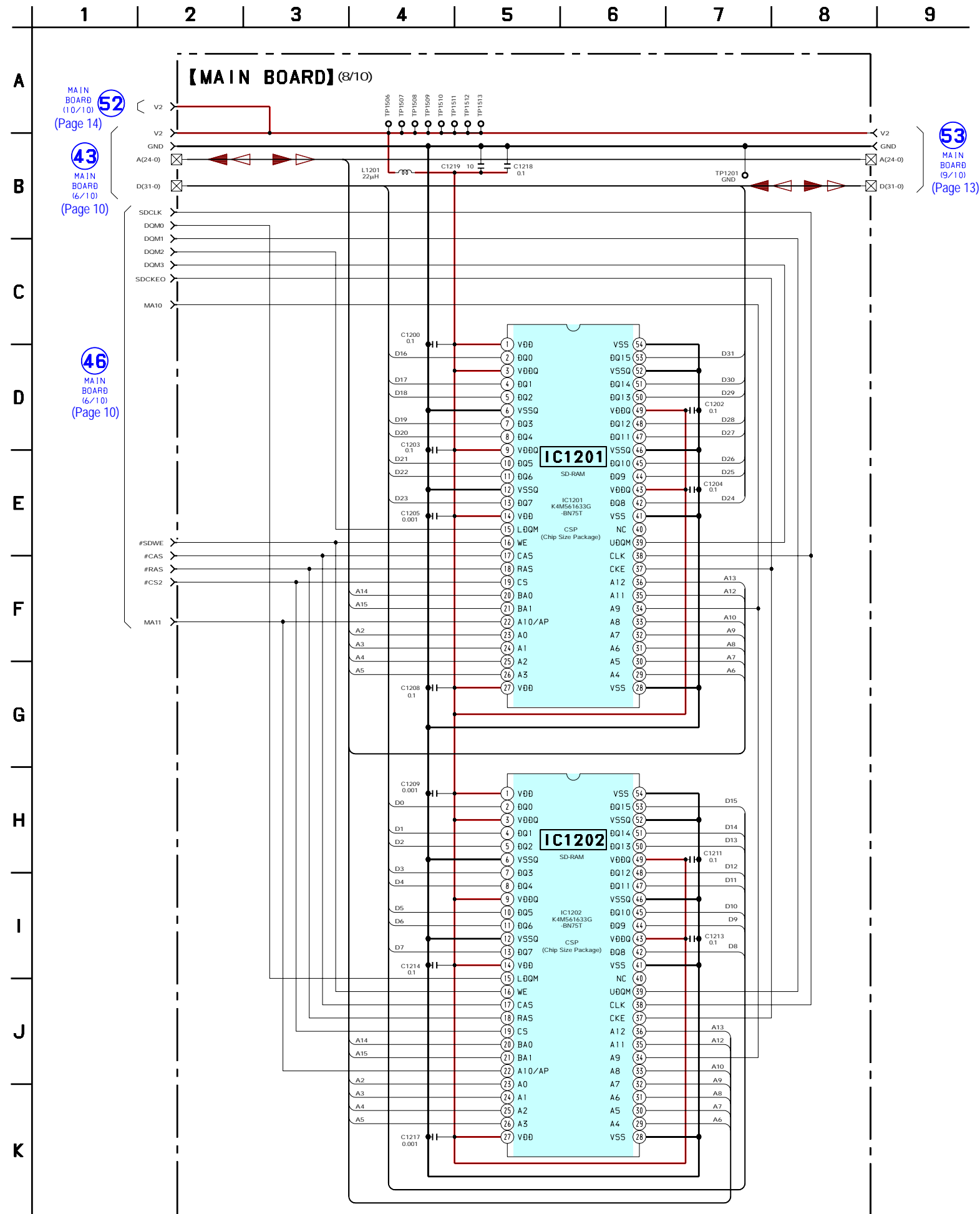

42 MAIN BOARD (10/10) (Page 14)

43 MAIN BOARD (6/10) (Page 10)

46 MAIN BOARD (6/10) (Page 10)

53 MAIN BOARD (9/10) (Page 13)

Note: When IC1201 and IC1202 on the MAIN board is damaged, exchange the new MAIN board for the MAIN board which IC damaged.

2-11. SCHEMATIC DIAGRAM - MAIN Board (9/10) -

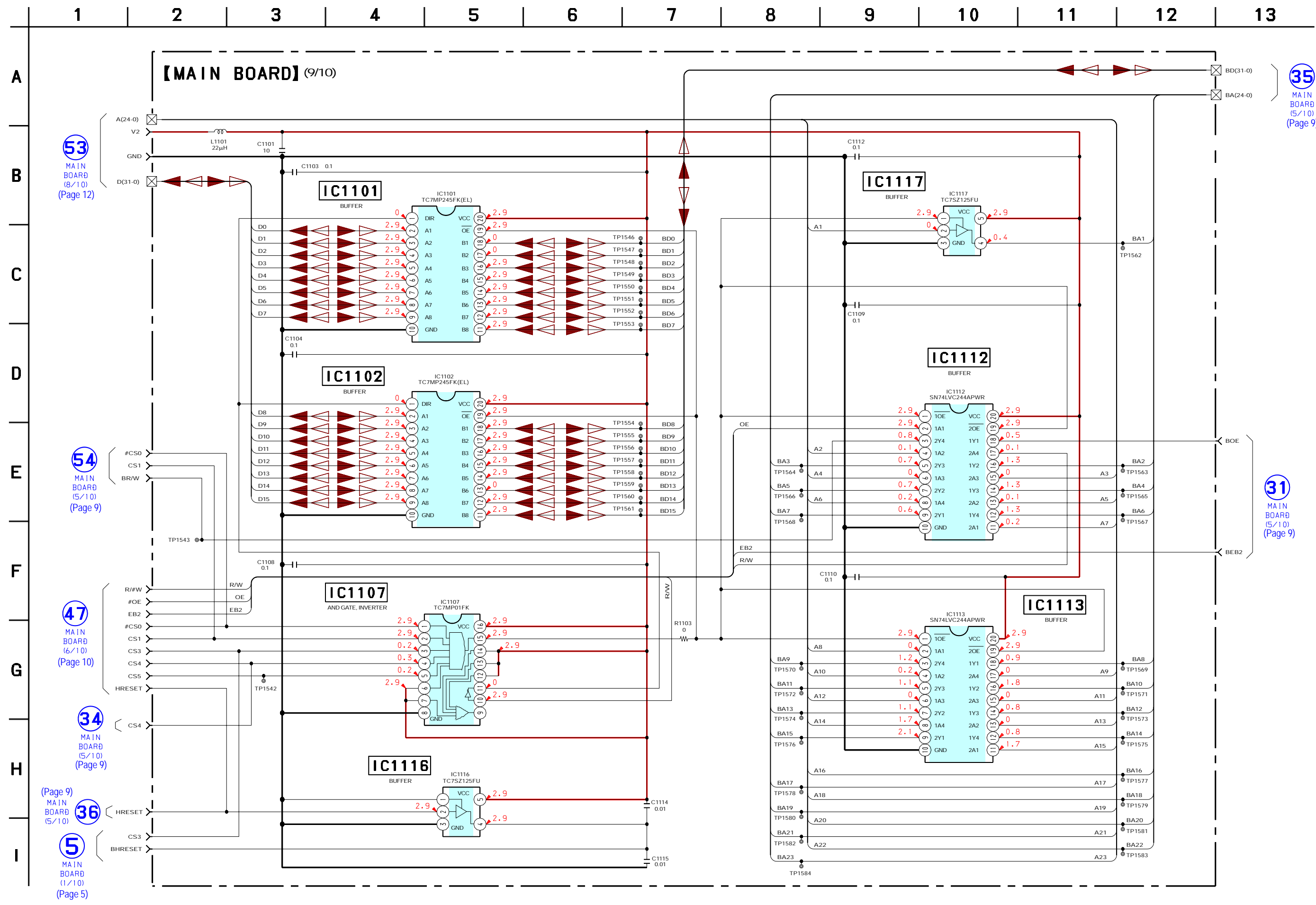

53 MAIN BOARD (8/10) (Page 12)

54 MAIN BOARD (5/10) (Page 9)

47 MAIN BOARD (6/10) (Page 10)

34 MAIN BOARD (5/10) (Page 9)

36 MAIN BOARD (5/10) (Page 9)

5 MAIN BOARD (1/10) (Page 5)

35 MAIN BOARD (5/10) (Page 9)

31 MAIN BOARD (5/10) (Page 9)

2-12. SCHEMATIC DIAGRAM - MAIN Board (10/10) -

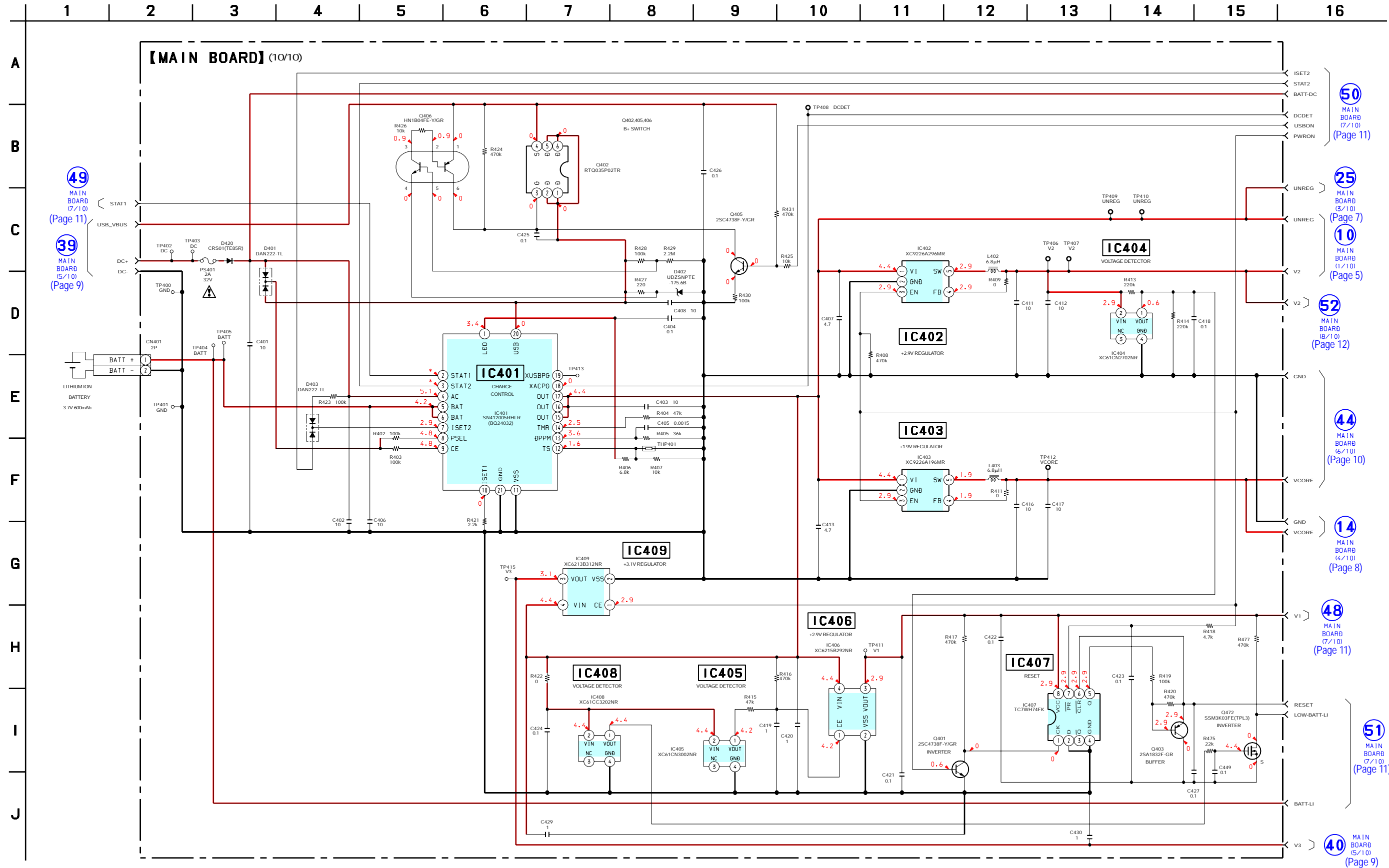

49 MAIN BOARD (7/10) (Page 11)

39 MAIN BOARD (5/10) (Page 9)

50 MAIN BOARD (7/10) (Page 11)

25 MAIN BOARD (5/10) (Page 7)

10 MAIN BOARD (1/10) (Page 5)

52 MAIN BOARD (8/10) (Page 12)

44 MAIN BOARD (6/10) (Page 10)

14 MAIN BOARD (4/10) (Page 8)

48 MAIN BOARD (7/10) (Page 11)

51 MAIN BOARD (7/10) (Page 11)

40 MAIN BOARD (5/10) (Page 9)

3. ELECTRICAL PARTS LIST

Note:

- Due to standardization, replacements in the parts list may be different from the parts specified in the diagrams or the components used on the set.
- -XX and -X mean standardized parts, so they may have some difference from the original one.
- Items marked "*" are not stocked since they are seldom required for routine service. Some delay should be anticipated when ordering these items.
- CAPACITORS
uF: µF
- COILS
uH: µH
- RESISTORS
All resistors are in ohms.
METAL: Metal-film resistor.
METAL OXIDE: Metal oxide-film resistor.
F: nonflammable
- SEMICONDUCTORS
In each case, u: µ, for example:
uA. . : µA. . , uPA. . , µPA. . ,
uPB. . : µPB. . , uPC. . , µPC. . ,
uPD. . : µPD. .

When indicating parts by reference number, please include the board name.

The components identified by mark \triangle or dotted line with mark \triangle are critical for safety.
Replace only with part number specified.

Les composants identifiés par une marque \triangle sont critiques pour la sécurité.
Ne les remplacer que par une pièce portant le numéro spécifié.

Ref. No.	Part No.	Description	Remark	Ref. No.	Part No.	Description	Remark
	X-2187-667-1	MAIN BOARD, COMPLETE (for SERVICE) *****		C219	1-100-506-91	CERAMIC CHIP 1uF 20%	6.3V
		< CAPACITOR >		C220	1-165-989-11	CERAMIC CHIP 10uF 10%	6.3V
C103	1-164-937-11	CERAMIC CHIP 0.001uF 10%	50V	C221	1-125-777-11	CERAMIC CHIP 0.1uF 10%	10V
C104	1-125-777-11	CERAMIC CHIP 0.1uF 10%	10V	C222	1-165-989-11	CERAMIC CHIP 10uF 10%	6.3V
C107	1-164-943-81	CERAMIC CHIP 0.01uF 10%	16V	C223	1-125-777-11	CERAMIC CHIP 0.1uF 10%	10V
C108	1-164-943-81	CERAMIC CHIP 0.01uF 10%	16V	C225	1-164-937-11	CERAMIC CHIP 0.001uF 10%	50V
C109	1-164-941-11	CERAMIC CHIP 0.0047uF 10%	16V	C226	1-125-777-11	CERAMIC CHIP 0.1uF 10%	10V
C110	1-125-777-11	CERAMIC CHIP 0.1uF 10%	10V	C227	1-164-943-81	CERAMIC CHIP 0.01uF 10%	16V
C111	1-165-989-11	CERAMIC CHIP 10uF 10%	6.3V	C228	1-125-777-11	CERAMIC CHIP 0.1uF 10%	10V
C112	1-125-777-11	CERAMIC CHIP 0.1uF 10%	10V	C301	1-100-506-91	CERAMIC CHIP 1uF 20%	6.3V
C113	1-125-777-11	CERAMIC CHIP 0.1uF 10%	10V	C302	1-100-506-91	CERAMIC CHIP 1uF 20%	6.3V
C114	1-125-777-11	CERAMIC CHIP 0.1uF 10%	10V	C303	1-100-506-91	CERAMIC CHIP 1uF 20%	6.3V
C115	1-165-989-11	CERAMIC CHIP 10uF 10%	6.3V	C304	1-100-506-91	CERAMIC CHIP 1uF 20%	6.3V
C116	1-165-908-11	CERAMIC CHIP 1uF 10%	10V	C305	1-125-777-11	CERAMIC CHIP 0.1uF 10%	10V
C117	1-165-989-11	CERAMIC CHIP 10uF 10%	6.3V	C306	1-125-777-11	CERAMIC CHIP 0.1uF 10%	10V
C118	1-165-989-11	CERAMIC CHIP 10uF 10%	6.3V	C308	1-125-777-11	CERAMIC CHIP 0.1uF 10%	10V
C119	1-165-989-11	CERAMIC CHIP 10uF 10%	6.3V	C309	1-100-506-91	CERAMIC CHIP 1uF 20%	6.3V
C120	1-125-777-11	CERAMIC CHIP 0.1uF 10%	10V	C310	1-115-339-11	CERAMIC CHIP 0.1uF 10%	50V
C121	1-125-777-11	CERAMIC CHIP 0.1uF 10%	10V	C311	1-119-869-91	CERAMIC CHIP 10uF	35V
C122	1-125-777-11	CERAMIC CHIP 0.1uF 10%	10V	C312	1-113-987-11	TANTALUM CHIP 4.7uF 20%	25V
C123	1-165-989-11	CERAMIC CHIP 10uF 10%	6.3V	C313	1-113-987-11	TANTALUM CHIP 4.7uF 20%	25V
C124	1-125-777-11	CERAMIC CHIP 0.1uF 10%	10V	C314	1-125-777-11	CERAMIC CHIP 0.1uF 10%	10V
C128	1-137-859-11	TANTALUM CHIP 220uF 20%	4V	C315	1-125-777-11	CERAMIC CHIP 0.1uF 10%	10V
C129	1-137-859-11	TANTALUM CHIP 220uF 20%	4V	C316	1-125-777-11	CERAMIC CHIP 0.1uF 10%	10V
C141	1-164-943-81	CERAMIC CHIP 0.01uF 10%	16V	C317	1-125-777-11	CERAMIC CHIP 0.1uF 10%	10V
C201	1-125-777-11	CERAMIC CHIP 0.1uF 10%	10V	C318	1-125-777-11	CERAMIC CHIP 0.1uF 10%	10V
C202	1-165-989-11	CERAMIC CHIP 10uF 10%	6.3V	C319	1-125-777-11	CERAMIC CHIP 0.1uF 10%	10V
C203	1-125-777-11	CERAMIC CHIP 0.1uF 10%	10V	C320	1-125-777-11	CERAMIC CHIP 0.1uF 10%	10V
C204	1-125-777-11	CERAMIC CHIP 0.1uF 10%	10V	C321	1-125-777-11	CERAMIC CHIP 0.1uF 10%	10V
C205	1-125-777-11	CERAMIC CHIP 0.1uF 10%	10V	C322	1-125-777-11	CERAMIC CHIP 0.1uF 10%	10V
C206	1-125-777-11	CERAMIC CHIP 0.1uF 10%	10V	C323	1-125-777-11	CERAMIC CHIP 0.1uF 10%	10V
C207	1-125-777-11	CERAMIC CHIP 0.1uF 10%	10V	C324	1-125-777-11	CERAMIC CHIP 0.1uF 10%	10V
C208	1-125-777-11	CERAMIC CHIP 0.1uF 10%	10V	C325	1-125-777-11	CERAMIC CHIP 0.1uF 10%	10V
C209	1-165-989-11	CERAMIC CHIP 10uF 10%	6.3V	C326	1-165-989-11	CERAMIC CHIP 10uF 10%	6.3V
C210	1-125-777-11	CERAMIC CHIP 0.1uF 10%	10V	C401	1-100-672-11	CERAMIC CHIP 10uF 20%	16V
C211	1-125-777-11	CERAMIC CHIP 0.1uF 10%	10V	C402	1-100-672-11	CERAMIC CHIP 10uF 20%	16V
C212	1-125-777-11	CERAMIC CHIP 0.1uF 10%	10V	C403	1-100-672-11	CERAMIC CHIP 10uF 20%	16V
C213	1-125-777-11	CERAMIC CHIP 0.1uF 10%	10V	C404	1-125-777-11	CERAMIC CHIP 0.1uF 10%	10V
C214	1-165-989-11	CERAMIC CHIP 10uF 10%	6.3V	C405	1-164-938-11	CERAMIC CHIP 0.0015uF 10%	50V
C215	1-125-777-11	CERAMIC CHIP 0.1uF 10%	10V	C406	1-100-672-11	CERAMIC CHIP 10uF 20%	16V
C216	1-100-506-91	CERAMIC CHIP 1uF 20%	6.3V	C407	1-127-760-11	CERAMIC CHIP 4.7uF 10%	6.3V
C217	1-100-506-91	CERAMIC CHIP 1uF 20%	6.3V	C408	1-100-672-11	CERAMIC CHIP 10uF 20%	16V
C218	1-100-506-91	CERAMIC CHIP 1uF 20%	6.3V	C411	1-165-989-11	CERAMIC CHIP 10uF 10%	6.3V
				C412	1-165-989-11	CERAMIC CHIP 10uF 10%	6.3V
				C413	1-127-760-11	CERAMIC CHIP 4.7uF 10%	6.3V

MAIN

Ref. No.	Part No.	Description			Remark	Ref. No.	Part No.	Description			Remark
C416	1-165-989-11	CERAMIC CHIP	10uF	10%	6.3V	C1018	1-165-989-11	CERAMIC CHIP	10uF	10%	6.3V
C417	1-165-989-11	CERAMIC CHIP	10uF	10%	6.3V	C1019	1-125-777-11	CERAMIC CHIP	0.1uF	10%	10V
C418	1-125-777-11	CERAMIC CHIP	0.1uF	10%	10V	C1020	1-125-777-11	CERAMIC CHIP	0.1uF	10%	10V
C419	1-100-506-91	CERAMIC CHIP	1uF	20%	6.3V	C1021	1-164-846-11	CERAMIC CHIP	6PF	0.5PF	50V
C420	1-100-506-91	CERAMIC CHIP	1uF	20%	6.3V	C1022	1-164-846-11	CERAMIC CHIP	6PF	0.5PF	50V
C421	1-125-777-11	CERAMIC CHIP	0.1uF	10%	10V	C1023	1-125-777-11	CERAMIC CHIP	0.1uF	10%	10V
C422	1-125-777-11	CERAMIC CHIP	0.1uF	10%	10V	C1024	1-125-777-11	CERAMIC CHIP	0.1uF	10%	10V
C423	1-125-777-11	CERAMIC CHIP	0.1uF	10%	10V	C1025	1-125-777-11	CERAMIC CHIP	0.1uF	10%	10V
C424	1-125-777-11	CERAMIC CHIP	0.1uF	10%	10V	C1028	1-125-777-11	CERAMIC CHIP	0.1uF	10%	10V
C425	1-164-156-11	CERAMIC CHIP	0.1uF		25V	C1029	1-125-777-11	CERAMIC CHIP	0.1uF	10%	10V
C426	1-164-156-11	CERAMIC CHIP	0.1uF		25V	C1030	1-125-777-11	CERAMIC CHIP	0.1uF	10%	10V
C427	1-125-777-11	CERAMIC CHIP	0.1uF	10%	10V	C1031	1-125-777-11	CERAMIC CHIP	0.1uF	10%	10V
C429	1-100-506-91	CERAMIC CHIP	1uF	20%	6.3V	C1032	1-164-943-81	CERAMIC CHIP	0.01uF	10%	16V
C430	1-100-506-91	CERAMIC CHIP	1uF	20%	6.3V	C1033	1-125-777-11	CERAMIC CHIP	0.1uF	10%	10V
C449	1-125-777-11	CERAMIC CHIP	0.1uF	10%	10V	C1034	1-125-777-11	CERAMIC CHIP	0.1uF	10%	10V
C801	1-165-989-11	CERAMIC CHIP	10uF	10%	6.3V	C1035	1-164-943-81	CERAMIC CHIP	0.01uF	10%	16V
C802	1-164-943-81	CERAMIC CHIP	0.01uF	10%	16V	C1036	1-125-777-11	CERAMIC CHIP	0.1uF	10%	10V
C803	1-164-943-81	CERAMIC CHIP	0.01uF	10%	16V	C1101	1-165-989-11	CERAMIC CHIP	10uF	10%	6.3V
C804	1-164-943-81	CERAMIC CHIP	0.01uF	10%	16V	C1103	1-125-777-11	CERAMIC CHIP	0.1uF	10%	10V
C805	1-164-943-81	CERAMIC CHIP	0.01uF	10%	16V	C1104	1-125-777-11	CERAMIC CHIP	0.1uF	10%	10V
C806	1-125-777-11	CERAMIC CHIP	0.1uF	10%	10V	C1108	1-125-777-11	CERAMIC CHIP	0.1uF	10%	10V
C807	1-164-848-11	CERAMIC CHIP	8PF	0.5PF	50V	C1109	1-125-777-11	CERAMIC CHIP	0.1uF	10%	10V
C808	1-164-848-11	CERAMIC CHIP	8PF	0.5PF	50V	C1110	1-125-777-11	CERAMIC CHIP	0.1uF	10%	10V
C809	1-125-777-11	CERAMIC CHIP	0.1uF	10%	10V	C1112	1-125-777-11	CERAMIC CHIP	0.1uF	10%	10V
C810	1-125-777-11	CERAMIC CHIP	0.1uF	10%	10V	C1113	1-125-777-11	CERAMIC CHIP	0.1uF	10%	10V
C811	1-805-216-21	VARISTOR, CHIP				C1114	1-164-943-81	CERAMIC CHIP	0.01uF	10%	16V
C812	1-805-216-21	VARISTOR, CHIP				C1115	1-164-943-81	CERAMIC CHIP	0.01uF	10%	16V
C813	1-805-216-21	VARISTOR, CHIP				C1120	1-165-989-11	CERAMIC CHIP	10uF	10%	6.3V
C954	1-165-989-11	CERAMIC CHIP	10uF	10%	6.3V	C1121	1-125-777-11	CERAMIC CHIP	0.1uF	10%	10V
C955	1-165-989-11	CERAMIC CHIP	10uF	10%	6.3V	C1124	1-125-777-11	CERAMIC CHIP	0.1uF	10%	10V
C956	1-165-989-11	CERAMIC CHIP	10uF	10%	6.3V	C1125	1-125-777-11	CERAMIC CHIP	0.1uF	10%	10V
C957	1-125-777-11	CERAMIC CHIP	0.1uF	10%	10V	C1200	1-125-777-11	CERAMIC CHIP	0.1uF	10%	10V
C958	1-125-777-11	CERAMIC CHIP	0.1uF	10%	10V	C1202	1-125-777-11	CERAMIC CHIP	0.1uF	10%	10V
C959	1-125-777-11	CERAMIC CHIP	0.1uF	10%	10V	C1203	1-125-777-11	CERAMIC CHIP	0.1uF	10%	10V
C960	1-125-777-11	CERAMIC CHIP	0.1uF	10%	10V	C1204	1-125-777-11	CERAMIC CHIP	0.1uF	10%	10V
C961	1-125-777-11	CERAMIC CHIP	0.1uF	10%	10V	C1205	1-164-937-11	CERAMIC CHIP	0.001uF	10%	50V
C962	1-125-777-11	CERAMIC CHIP	0.1uF	10%	10V	C1206	1-125-777-11	CERAMIC CHIP	0.1uF	10%	10V
C963	1-125-777-11	CERAMIC CHIP	0.1uF	10%	10V	C1208	1-125-777-11	CERAMIC CHIP	0.1uF	10%	10V
C964	1-125-777-11	CERAMIC CHIP	0.1uF	10%	10V	C1209	1-164-937-11	CERAMIC CHIP	0.001uF	10%	50V
C965	1-164-854-11	CERAMIC CHIP	15PF	5%	50V	C1211	1-125-777-11	CERAMIC CHIP	0.1uF	10%	10V
C966	1-164-856-81	CERAMIC CHIP	18PF	5%	50V	C1213	1-125-777-11	CERAMIC CHIP	0.1uF	10%	10V
C967	1-100-352-91	CERAMIC CHIP	1uF	20%	16V	C1214	1-125-777-11	CERAMIC CHIP	0.1uF	10%	10V
C968	1-164-943-81	CERAMIC CHIP	0.01uF	10%	16V	C1217	1-164-937-11	CERAMIC CHIP	0.001uF	10%	50V
C969	1-125-777-11	CERAMIC CHIP	0.1uF	10%	10V	C1218	1-125-777-11	CERAMIC CHIP	0.1uF	10%	10V
C970	1-125-777-11	CERAMIC CHIP	0.1uF	10%	10V	C1219	1-165-989-11	CERAMIC CHIP	10uF	10%	6.3V
C1003	1-110-569-11	TANTALUM CHIP	47uF	20%	6.3V	C1220	1-165-989-11	CERAMIC CHIP	10uF	10%	6.3V
C1004	1-125-777-11	CERAMIC CHIP	0.1uF	10%	10V	C1221	1-125-777-11	CERAMIC CHIP	0.1uF	10%	10V
C1005	1-128-964-91	TANTALUM CHIP	100uF	20%	6.3V	C1801	1-164-939-11	CERAMIC CHIP	0.0022uF	10%	50V
C1006	1-125-777-11	CERAMIC CHIP	0.1uF	10%	10V	C1804	1-100-703-91	CERAMIC CHIP	10uF	10%	25V
C1007	1-125-777-11	CERAMIC CHIP	0.1uF	10%	10V	C1805	1-100-703-91	CERAMIC CHIP	10uF	10%	25V
C1008	1-125-777-11	CERAMIC CHIP	0.1uF	10%	10V	C1806	1-100-703-91	CERAMIC CHIP	10uF	10%	25V
C1009	1-125-777-11	CERAMIC CHIP	0.1uF	10%	10V	C1808	1-104-913-11	TANTALUM CHIP	10uF	20%	16V
C1010	1-125-777-11	CERAMIC CHIP	0.1uF	10%	10V	C1809	1-104-913-11	TANTALUM CHIP	10uF	20%	16V
C1011	1-125-777-11	CERAMIC CHIP	0.1uF	10%	10V	C1810	1-100-352-91	CERAMIC CHIP	1uF	20%	16V
C1012	1-125-777-11	CERAMIC CHIP	0.1uF	10%	10V	C1812	1-165-887-91	CERAMIC CHIP	0.22uF	10%	6.3V
C1013	1-125-777-11	CERAMIC CHIP	0.1uF	10%	10V	C1814	1-100-162-91	CERAMIC CHIP	1uF		50V
C1014	1-125-777-11	CERAMIC CHIP	0.1uF	10%	10V	C1816	1-164-005-11	CERAMIC CHIP	0.47uF		25V
C1015	1-125-777-11	CERAMIC CHIP	0.1uF	10%	10V	C1818	1-100-162-91	CERAMIC CHIP	1uF		50V
C1016	1-125-777-11	CERAMIC CHIP	0.1uF	10%	10V	C1819	1-125-777-11	CERAMIC CHIP	0.1uF	10%	10V
C1017	1-125-777-11	CERAMIC CHIP	0.1uF	10%	10V	C1821	1-164-156-11	CERAMIC CHIP	0.1uF		25V

MAIN

Ref. No.	Part No.	Description	Remark			Ref. No.	Part No.	Description	Remark		
Q402	6-550-354-01	TRANSISTOR	RTQ035P02TR			R303	1-218-990-81	SHORT CHIP	0		
Q403	6-550-254-01	TRANSISTOR	2SA1832F-GR (T3SOYF			R322	1-218-985-11	RES-CHIP	470K	5%	1/16W
Q405	8-729-037-52	TRANSISTOR	2SD2216J-QR (TX).SO			R326	1-218-990-81	SHORT CHIP	0		
Q406	8-729-054-48	TRANSISTOR	UP04601008S0			R327	1-218-990-81	SHORT CHIP	0		
Q472	8-729-047-68	FET	SSM3K03FE (TPL3)			R328	1-218-990-81	SHORT CHIP	0		
Q801	6-550-747-01	FET	3LP01S-K-TL-E			R330	1-218-990-81	SHORT CHIP	0		
Q802	8-729-047-68	FET	SSM3K03FE (TPL3)			R332	1-218-985-11	RES-CHIP	470K	5%	1/16W
Q1001	8-729-037-52	TRANSISTOR	2SD2216J-QR (TX).SO			R333	1-218-947-11	RES-CHIP	330	5%	1/16W
Q1802	8-729-037-52	TRANSISTOR	2SD2216J-QR (TX).SO			R334	1-218-941-81	RES-CHIP	100	5%	1/16W
Q1804	6-550-761-01	TRANSISTOR	SSM6J07FU (TE85R)			R336	1-218-985-11	RES-CHIP	470K	5%	1/16W
Q1805	8-729-037-52	TRANSISTOR	2SD2216J-QR (TX).SO			R337	1-218-947-11	RES-CHIP	330	5%	1/16W
Q1806	8-729-037-52	TRANSISTOR	2SD2216J-QR (TX).SO			R349	1-218-941-81	RES-CHIP	100	5%	1/16W
Q1809	6-550-254-01	TRANSISTOR	2SA1832F-GR (T3SOYF			R355	1-218-990-81	SHORT CHIP	0		
Q1814	8-729-054-48	TRANSISTOR	UP04601008S0			R364	1-218-953-11	RES-CHIP	1K	5%	1/16W
Q1822	8-729-023-89	FET	2SJ305 (TE85L)			R365	1-218-990-81	SHORT CHIP	0		
		< RESISTOR/FERRITE BEAD/THERMISTOR >				R376	1-218-990-81	SHORT CHIP	0		
						R377	1-218-990-81	SHORT CHIP	0		
R101	1-218-977-11	RES-CHIP	100K	5%	1/16W	R378	1-218-990-81	SHORT CHIP	0		
R102	1-218-989-11	RES-CHIP	1M	5%	1/16W	R379	1-218-990-81	SHORT CHIP	0		
R103	1-218-961-11	RES-CHIP	4.7K	5%	1/16W	R380	1-218-990-81	SHORT CHIP	0		
R104	1-218-961-11	RES-CHIP	4.7K	5%	1/16W	R381	1-218-990-81	SHORT CHIP	0		
R106	1-218-965-11	RES-CHIP	10K	5%	1/16W	R382	1-218-990-81	SHORT CHIP	0		
R107	1-218-929-11	RES-CHIP	10	5%	1/16W	R383	1-218-990-81	SHORT CHIP	0		
R108	1-218-929-11	RES-CHIP	10	5%	1/16W	R384	1-218-990-81	SHORT CHIP	0		
R109	1-218-929-11	RES-CHIP	10	5%	1/16W	R385	1-218-990-81	SHORT CHIP	0		
R110	1-218-949-11	RES-CHIP	470	5%	1/16W	R386	1-218-990-81	SHORT CHIP	0		
R116	1-218-947-11	RES-CHIP	330	5%	1/16W	R387	1-218-953-11	RES-CHIP	1K	5%	1/16W
R117	1-218-941-81	RES-CHIP	100	5%	1/16W	R388	1-218-953-11	RES-CHIP	1K	5%	1/16W
* R120	1-469-230-21	BEAD, FERRITE (1005)				R389	1-218-953-11	RES-CHIP	1K	5%	1/16W
* R122	1-469-230-21	BEAD, FERRITE (1005)				R402	1-218-977-11	RES-CHIP	100K	5%	1/16W
R129	1-216-864-11	SHORT CHIP	0			R403	1-218-977-11	RES-CHIP	100K	5%	1/16W
R203	1-218-990-81	SHORT CHIP	0			R404	1-218-973-11	RES-CHIP	47K	5%	1/16W
R204	1-218-990-81	SHORT CHIP	0			R405	1-208-720-11	METAL CHIP	36K	0.5%	1/16W
R205	1-218-990-81	SHORT CHIP	0			R406	1-208-703-11	METAL CHIP	6.8K	0.5%	1/16W
R206	1-218-953-11	RES-CHIP	1K	5%	1/16W	R407	1-208-911-11	METAL CHIP	10K	0.5%	1/16W
R207	1-218-945-11	RES-CHIP	220	5%	1/16W	R408	1-218-985-11	RES-CHIP	470K	5%	1/16W
R208	1-218-945-11	RES-CHIP	220	5%	1/16W	R409	1-218-990-81	SHORT CHIP	0		
R209	1-218-990-81	SHORT CHIP	0			R411	1-218-990-81	SHORT CHIP	0		
R210	1-218-941-81	RES-CHIP	100	5%	1/16W	R413	1-218-981-91	RES-CHIP	220K	5%	1/16W
R219	1-218-977-11	RES-CHIP	100K	5%	1/16W	R414	1-218-981-91	RES-CHIP	220K	5%	1/16W
R223	1-218-941-81	RES-CHIP	100	5%	1/16W	R415	1-218-973-11	RES-CHIP	47K	5%	1/16W
R224	1-218-985-11	RES-CHIP	470K	5%	1/16W	R416	1-218-985-11	RES-CHIP	470K	5%	1/16W
R240	1-400-827-31	BEAD, FERRITE (1005)				R417	1-218-985-11	RES-CHIP	470K	5%	1/16W
R241	1-400-827-31	BEAD, FERRITE (1005)				R418	1-218-961-11	RES-CHIP	4.7K	5%	1/16W
R242	1-400-827-31	BEAD, FERRITE (1005)				R419	1-218-977-11	RES-CHIP	100K	5%	1/16W
R243	1-400-827-31	BEAD, FERRITE (1005)				R420	1-218-985-11	RES-CHIP	470K	5%	1/16W
R244	1-400-827-31	BEAD, FERRITE (1005)				R421	1-208-691-11	METAL CHIP	2.2K	0.5%	1/16W
R245	1-400-827-31	BEAD, FERRITE (1005)				R422	1-218-990-81	SHORT CHIP	0		
R246	1-218-990-81	SHORT CHIP	0			R423	1-218-977-11	RES-CHIP	100K	5%	1/16W
R247	1-218-990-81	SHORT CHIP	0			R424	1-218-985-11	RES-CHIP	470K	5%	1/16W
R248	1-400-827-31	BEAD, FERRITE (1005)				R425	1-218-965-11	RES-CHIP	10K	5%	1/16W
R249	1-400-827-31	BEAD, FERRITE (1005)				R426	1-218-965-11	RES-CHIP	10K	5%	1/16W
R250	1-400-827-31	BEAD, FERRITE (1005)				R427	1-218-945-11	RES-CHIP	220	5%	1/16W
R251	1-400-827-31	BEAD, FERRITE (1005)				R428	1-218-977-11	RES-CHIP	100K	5%	1/16W
R252	1-218-990-81	SHORT CHIP	0			R429	1-220-804-11	RES-CHIP	2.2M	5%	1/16W
R253	1-400-827-31	BEAD, FERRITE (1005)				R430	1-218-977-11	RES-CHIP	100K	5%	1/16W
R254	1-400-827-31	BEAD, FERRITE (1005)				R431	1-218-985-11	RES-CHIP	470K	5%	1/16W
R255	1-218-985-11	RES-CHIP	470K	5%	1/16W	R475	1-218-969-11	RES-CHIP	22K	5%	1/16W
R301	1-218-990-81	SHORT CHIP	0			R477	1-218-985-11	RES-CHIP	470K	5%	1/16W
R302	1-218-985-11	RES-CHIP	470K	5%	1/16W	R801	1-218-965-11	RES-CHIP	10K	5%	1/16W

Ref. No.	Part No.	Description			Remark	Ref. No.	Part No.	Description			Remark
R802	1-218-965-11	RES-CHIP	10K	5%	1/16W	R1829	1-208-683-11	METAL CHIP	1K	0.5%	1/16W
R803	1-218-941-81	RES-CHIP	100	5%	1/16W	R1832	1-208-683-11	METAL CHIP	1K	0.5%	1/16W
R804	1-218-941-81	RES-CHIP	100	5%	1/16W	R1835	1-208-711-11	METAL CHIP	15K	0.5%	1/16W
R805	1-218-941-81	RES-CHIP	100	5%	1/16W	R1836	1-218-970-11	RES-CHIP	27K	5%	1/16W
R806	1-218-985-11	RES-CHIP	470K	5%	1/16W	R1837	1-208-668-11	METAL CHIP	240	0.5%	1/16W
R807	1-218-985-11	RES-CHIP	470K	5%	1/16W	R1840	1-218-959-11	RES-CHIP	3.3K	5%	1/16W
R808	1-218-985-11	RES-CHIP	470K	5%	1/16W	R1841	1-218-961-11	RES-CHIP	4.7K	5%	1/16W
R809	1-218-985-11	RES-CHIP	470K	5%	1/16W	R1842	1-218-973-11	RES-CHIP	47K	5%	1/16W
R810	1-218-977-11	RES-CHIP	100K	5%	1/16W	R1843	1-218-965-11	RES-CHIP	10K	5%	1/16W
R811	1-218-941-81	RES-CHIP	100	5%	1/16W	R1844	1-208-922-11	METAL CHIP	30K	0.5%	1/16W
R812	1-218-990-81	SHORT CHIP	0			R1845	1-208-711-11	METAL CHIP	15K	0.5%	1/16W
R813	1-218-941-81	RES-CHIP	100	5%	1/16W	R1846	1-208-683-11	METAL CHIP	1K	0.5%	1/16W
R814	1-218-953-11	RES-CHIP	1K	5%	1/16W	R1847	1-218-989-11	RES-CHIP	1M	5%	1/16W
R815	1-218-985-11	RES-CHIP	470K	5%	1/16W	R1848	1-218-977-11	RES-CHIP	100K	5%	1/16W
R816	1-218-953-11	RES-CHIP	1K	5%	1/16W	R1849	1-218-953-11	RES-CHIP	1K	5%	1/16W
R817	1-218-985-11	RES-CHIP	470K	5%	1/16W	R1860	1-245-115-91	METAL CHIP	100K	0.1%	1/10W
R819	1-218-985-11	RES-CHIP	470K	5%	1/16W	R1861	1-245-115-91	METAL CHIP	100K	0.1%	1/10W
R821	1-218-985-11	RES-CHIP	470K	5%	1/16W	R1863	1-208-911-11	METAL CHIP	10K	0.5%	1/16W
R822	1-208-912-11	METAL CHIP	11K	0.5%	1/16W	R1864	1-218-987-11	RES-CHIP	680K	5%	1/16W
R824	1-218-941-81	RES-CHIP	100	5%	1/16W	R1876	1-208-911-11	METAL CHIP	10K	0.5%	1/16W
R825	1-218-965-11	RES-CHIP	10K	5%	1/16W	R1880	1-218-965-11	RES-CHIP	10K	5%	1/16W
R826	1-208-715-11	METAL CHIP	22K	0.5%	1/16W	R1881	1-218-977-11	RES-CHIP	100K	5%	1/16W
R827	1-218-977-11	RES-CHIP	100K	5%	1/16W	R1882	1-218-965-11	RES-CHIP	10K	5%	1/16W
R828	1-218-977-11	RES-CHIP	100K	5%	1/16W	R1883	1-208-911-11	METAL CHIP	10K	0.5%	1/16W
R829	1-218-959-11	RES-CHIP	3.3K	5%	1/16W	R1884	1-218-965-11	RES-CHIP	10K	5%	1/16W
R833	1-218-989-11	RES-CHIP	1M	5%	1/16W	R1885	1-218-977-11	RES-CHIP	100K	5%	1/16W
R836	1-218-985-11	RES-CHIP	470K	5%	1/16W	R1886	1-218-985-11	RES-CHIP	56K	5%	1/16W
R837	1-218-985-11	RES-CHIP	470K	5%	1/16W	R1887	1-218-985-11	RES-CHIP	56K	5%	1/16W
R840	1-218-941-81	RES-CHIP	100	5%	1/16W	R1888	1-218-977-11	RES-CHIP	100K	5%	1/16W
R842	1-218-941-81	RES-CHIP	100	5%	1/16W	R1889	1-218-965-11	RES-CHIP	10K	5%	1/16W
R851	1-218-953-11	RES-CHIP	1K	5%	1/16W	R1890	1-208-715-11	METAL CHIP	22K	0.5%	1/16W
R856	1-218-941-81	RES-CHIP	100	5%	1/16W	R1891	1-208-923-11	METAL CHIP	33K	0.5%	1/16W
R857	1-218-941-81	RES-CHIP	100	5%	1/16W	R1892	1-218-977-11	RES-CHIP	100K	5%	1/16W
R954	1-218-947-11	RES-CHIP	330	5%	1/16W	R1893	1-218-977-11	RES-CHIP	100K	5%	1/16W
R956	1-218-990-81	SHORT CHIP	0			R1894	1-208-920-81	METAL CHIP	24K	0.5%	1/16W
R957	1-218-990-81	SHORT CHIP	0			R1895	1-218-970-11	RES-CHIP	27K	5%	1/16W
R958	1-218-990-81	SHORT CHIP	0			R1898	1-218-953-11	RES-CHIP	1K	5%	1/16W
R959	1-218-977-11	RES-CHIP	100K	5%	1/16W	R1899	1-218-941-81	RES-CHIP	100	5%	1/16W
R960	1-218-977-11	RES-CHIP	100K	5%	1/16W	R1907	1-218-977-11	RES-CHIP	100K	5%	1/16W
R961	1-218-977-11	RES-CHIP	100K	5%	1/16W	R1908	1-218-977-11	RES-CHIP	100K	5%	1/16W
R962	1-208-906-81	METAL CHIP	6.2K	0.5%	1/16W	R1910	1-218-990-81	SHORT CHIP	0		
R965	1-218-929-11	RES-CHIP	10	5%	1/16W	R2010	1-218-951-11	RES-CHIP	680	5%	1/16W
R967	1-218-977-11	RES-CHIP	100K	5%	1/16W	R2013	1-218-941-81	RES-CHIP	100	5%	1/16W
R968	1-218-977-11	RES-CHIP	100K	5%	1/16W	R2019	1-218-947-11	RES-CHIP	330	5%	1/16W
R969	1-218-976-11	RES-CHIP	82K	5%	1/16W	R2020	1-218-947-11	RES-CHIP	330	5%	1/16W
R970	1-218-976-11	RES-CHIP	82K	5%	1/16W	R2021	1-218-947-11	RES-CHIP	330	5%	1/16W
R971	1-805-719-12	THERMISTOR, POSITIVE				R2101	1-218-953-11	RES-CHIP	1K	5%	1/16W
R1103	1-218-990-81	SHORT CHIP	0			R2102	1-218-953-11	RES-CHIP	1K	5%	1/16W
R1298	1-218-985-11	RES-CHIP	470K	5%	1/16W	R2103	1-218-941-81	RES-CHIP	100	5%	1/16W
R1802	1-216-864-11	SHORT CHIP	0			R2104	1-218-941-81	RES-CHIP	100	5%	1/16W
R1807	1-218-965-11	RES-CHIP	10K	5%	1/16W	R2105	1-218-929-11	RES-CHIP	10	5%	1/16W
R1814	1-218-953-11	RES-CHIP	1K	5%	1/16W	R2119	1-218-965-11	RES-CHIP	10K	5%	1/16W
R1815	1-218-987-11	RES-CHIP	680K	5%	1/16W	R2208	1-218-977-11	RES-CHIP	100K	5%	1/16W
R1816	1-218-977-11	RES-CHIP	100K	5%	1/16W	R2214	1-218-965-11	RES-CHIP	10K	5%	1/16W
R1821	1-208-935-11	METAL CHIP	100K	0.5%	1/16W	R2215	1-218-965-11	RES-CHIP	10K	5%	1/16W
R1823	1-208-920-81	METAL CHIP	24K	0.5%	1/16W	R2216	1-218-965-11	RES-CHIP	10K	5%	1/16W
R1824	1-208-933-11	METAL CHIP	82K	0.5%	1/16W	R2219	1-218-965-11	RES-CHIP	10K	5%	1/16W
R1826	1-208-912-11	METAL CHIP	11K	0.5%	1/16W	R2238	1-218-965-11	RES-CHIP	10K	5%	1/16W
R1827	1-208-934-11	METAL CHIP	91K	0.5%	1/16W	R2239	1-218-965-11	RES-CHIP	10K	5%	1/16W
R1828	1-208-922-11	METAL CHIP	30K	0.5%	1/16W	R2264	1-218-977-11	RES-CHIP	100K	5%	1/16W

PRS-505

MAIN

Ref. No.	Part No.	Description			Remark
R2267	1-218-977-11	RES-CHIP	100K	5%	1/16W
R2268	1-218-977-11	RES-CHIP	100K	5%	1/16W
R2527	1-218-947-11	RES-CHIP	330	5%	1/16W
< COMPOSITION CIRCUIT BLOCK >					
RB201	1-234-372-11	RES, NETWORK	100	(1005X4)	
RB202	1-234-372-11	RES, NETWORK	100	(1005X4)	
RB203	1-234-372-11	RES, NETWORK	100	(1005X4)	
RB301	1-234-372-11	RES, NETWORK	100	(1005X4)	
RB302	1-234-372-11	RES, NETWORK	100	(1005X4)	
RB303	1-234-372-11	RES, NETWORK	100	(1005X4)	
RB304	1-234-372-11	RES, NETWORK	100	(1005X4)	
RB801	1-234-372-11	RES, NETWORK	100	(1005X4)	
RB802	1-234-372-11	RES, NETWORK	100	(1005X4)	
RB803	1-234-372-11	RES, NETWORK	100	(1005X4)	
RB804	1-234-372-11	RES, NETWORK	100	(1005X4)	
RB805	1-234-379-21	RES, NETWORK	22K	(1005X4)	
RB806	1-234-379-21	RES, NETWORK	22K	(1005X4)	
RB807	1-234-379-21	RES, NETWORK	22K	(1005X4)	
RB808	1-234-379-21	RES, NETWORK	22K	(1005X4)	
RB2001	1-234-372-11	RES, NETWORK	100	(1005X4)	
RB2002	1-234-372-11	RES, NETWORK	100	(1005X4)	
RB2003	1-234-372-11	RES, NETWORK	100	(1005X4)	
RB2004	1-234-372-11	RES, NETWORK	100	(1005X4)	
RB2005	1-234-372-11	RES, NETWORK	100	(1005X4)	
RB2006	1-234-387-21	RES, NETWORK	330	(1005X4)	
RB2007	1-234-372-11	RES, NETWORK	100	(1005X4)	
RB2008	1-234-383-21	RES, NETWORK	470K	(1005X4)	
RB2009	1-234-383-21	RES, NETWORK	470K	(1005X4)	
RB2010	1-234-383-21	RES, NETWORK	470K	(1005X4)	
RB2011	1-234-387-21	RES, NETWORK	330	(1005X4)	
RB2012	1-234-387-21	RES, NETWORK	330	(1005X4)	
RB2013	1-234-387-21	RES, NETWORK	330	(1005X4)	
RB2014	1-234-383-21	RES, NETWORK	470K	(1005X4)	
RB2015	1-234-383-21	RES, NETWORK	470K	(1005X4)	
RB2016	1-234-383-21	RES, NETWORK	470K	(1005X4)	
< VARIABLE RESISTOR >					
RV1801	1-225-901-21	RES, ADJ, CERMET (3 TYPE)	10K		
< SWITCH >					
S801	1-786-515-21	SWITCH, TACTILE (RESET)			
S873	1-786-293-21	SWITCH, TACTILE (VOL -)			
S874	1-786-293-21	SWITCH, TACTILE (VOL +)			
< COIL >					
T951	1-400-284-21	COIL, COMMON MODE CHOKE			
< THERMISTOR (POSITIVE) >					
THP401	1-804-949-11	THERMISTOR, NTC (SMD)			
< VIBRATOR >					
X102	1-813-180-21	VIBRATOR, CERAMIC (11.2896MHz)			
X801	1-795-029-11	VIBRATOR, CRYSTAL (32.768kHz)			
X802	1-813-181-21	VIBRATOR, CERAMIC (4.9152MHz)			
X951	1-813-877-11	VIBRATOR, CRYSTAL (12MHz)			
X1002	1-795-029-11	VIBRATOR, CRYSTAL (32.768kHz)			

MEMO

